

Ultrasonic Flowmeter and Analyzer

Model: D118i



Update	Revision	1.02
Record	Date	11. 2015

Notice

Thank you for choosing the D118i Ultrasonic Flowmeter and Analyzer with ARM chip and low-voltage wide-pulse sending technology.

This instruction manual contains important information. Please read it carefully before operation the flowmeter thus avoiding damage to the flowmeter from improper use.

This instruction manual will advise how to use the flowmeter step-by-step manner, including product component description, installation, wiring and quick setup etc. to make it easier to operate.

A working knowledge of the menu settings will assist you in understanding the flowmeters' powerful and output function.



Warning

May cause injury.



Attention

May damage the flow meter.

Some of the instructions may be different from the flowmeter and analyzer you have purchased. That depends on the configuration requirements. It also may be due to changes in product design, modification and upgrade .You will find the flowmeter display interface intuitive and easy to understand and it shall prevail when there is no indication of the instructions. Please refer to the version number and the appendix for more information.

Product Components

Inspection should be made before installing the flowmeter. Check to see if the spare parts are in accordance with the packing list. Make sure that there is no damage to the enclosure due to loose screw or wires or other damage that may have occurred during transportation. Any questions, please contact your representative as soon as possible.

Transmitter	Transducer
	
Accessories	Documents
	 <ol style="list-style-type: none"> 1. Instruction 2. Packing List

Content

1. Transmitter Installation and Connection.....	6
1.1 Transmitter Installation and Wire Connecting.....	6
1.1.1 Transmitter Installation	6
1.1.2 Power Supply Option	7
1.1.3 Transmitter Wiring	7
1.2 Powering On.....	8
1.3 Keypad.....	8
1.4 Keypad Operation.....	9
1.5 Flowmeter and Analyzer Window Descriptions	10
2. The Quick Setup Description.....	10
2.1 The Quick Setup Instructions	10
2.2 The Shortcut Menu Descriptions	13
2.3 Setup Menu Description	20
2.4 Measurement Site Selection	22
3. Transducer Installation	24
3.1 Installing the Transducer	24
3.2 Transducer Mounting Methods.....	24
3.2.1 V Method.....	24
3.2.2 Z Method.....	24
3.2.3 N Method (not commonly used).....	25
3.3 Transducer Installation and Fixing	25
3.3.1 Transducer Pipe Hoop Installation	25
3.3.2 Transducer Cable Ties Installation	26
3.4 Transducer Mounting Inspection	28
3.4.1 Signal Strength	28
3.4.2 Signal Quality (Q value).....	28
3.4.3 Total Time and Delta Time	28
3.4.4 Transit Time Ratio	28
3.4.5 Warnings.....	28
4. Operating Instructions	29
4.1 System Normal Identification.....	29
4.2 Low Flow Cutoff Value	29
4.3 Zero Settings.....	29
4.4 Scale Factor	29
4.5 4 ~ 20mA Current Loop Output.....	29
4.6 4-20mA Analog Output Calibration.....	30
4.7 TF Card Operation.....	30
4.7.1 Specifications	30

4.7.2 Reading the TF Data Offline 31

4.7.3 TF Card Storage Operation Guide 31

4.8 ESN 32

5. Windows Display Explanation 33

6. Error Diagnoses 48

6.1 Frequently Asked Questions and Answers 48

7. Product Overview 48

7.1 Introduction 48

7.2 Features of D118i 48

7.3 Theory of Operation 48

7.4 Applications 49

7.5 Specifications 50

8. Appendix1- Flow Application Data 51

8.1 Sound Velocity and Viscosity for Fluids Commonly Used 51

8.2 Sound Velocity for Various Materials Commonly Used 51

8.3 Sound Velocity in Water (1 atm) at different temperatures 52

9. Appendix2– Network and Communications Protocol 53

9.1 Overview 53

9.2 Serial Port Definitions 53

9.3 RS232 Connection 54

9.4 Communications Protocol And The Use 54

9.4.1 FUJI Protocol 54

9.4.2 Function Prefix And Function Sign 56

9.4.3 MODBUS Communication Protocol 56

9.4.4 MODBUS Register Address List 59

Update information:

1. Transmitter Installation and Connection

1.1 Transmitter Installation and Wire Connecting

1.1.1 Transmitter Installation

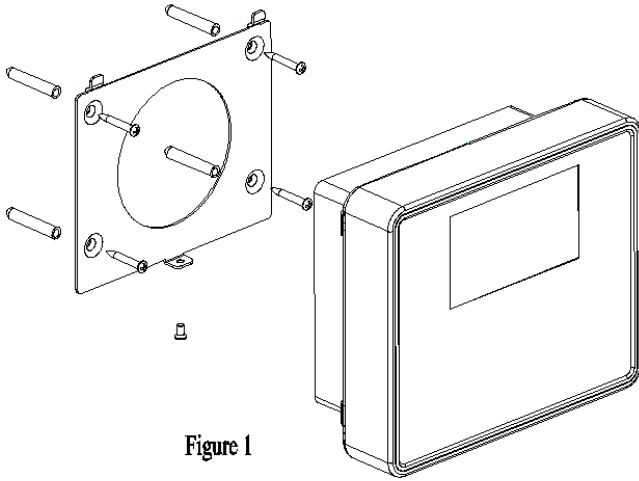
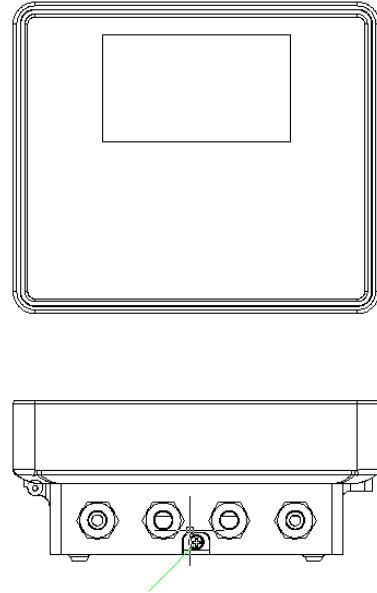

Figure 1
Host Installation Exploded Views



M4 countersink screw
Figure 2

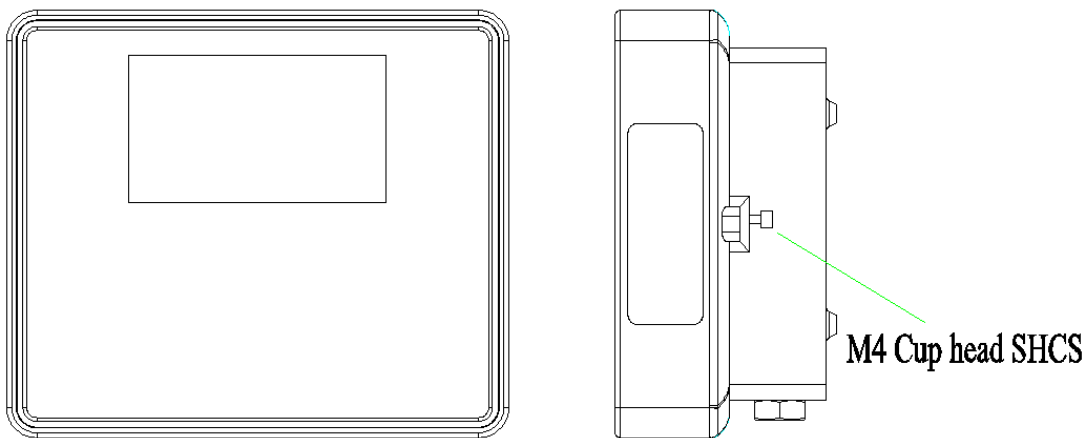

Figure 3

1. Fix the mounting bracket on the wall with rubber plug screw (see Figure 1)
2. Fix the host on the mounting bracket with M4 countersink screws (see Figure 2).
3. Uncover the host for wire connection, unscrew the M4 Cup Head SHCS (see Figure 3).

1.1.2 Power Supply Option

90~250VAC@48~63Hz or 10~36VDC

1.1.3 Transmitter Wiring

Once the electronics enclosure has been installed, the flowmeter wiring can be connected.

Open the case. You will find the Power board wiring ports, from left to right, are as follows;

1st layer: RS485B Interface (for expansion), Analog Input, RS232 and RTD Temperature Transducer Input (for expansion)

2nd layer: AC power (90-245V), DC power (10-36V), Upstream Transducer Interface, Downstream Transducer Interface, Relay Output, OCT Output, 4-20mA Output and RS485A Interface.

For double-shielded transducer cable: "-" on the black wire, "+" on the red wire and "shield" on the shield wire.

Refer to the below diagram for specific connection information:

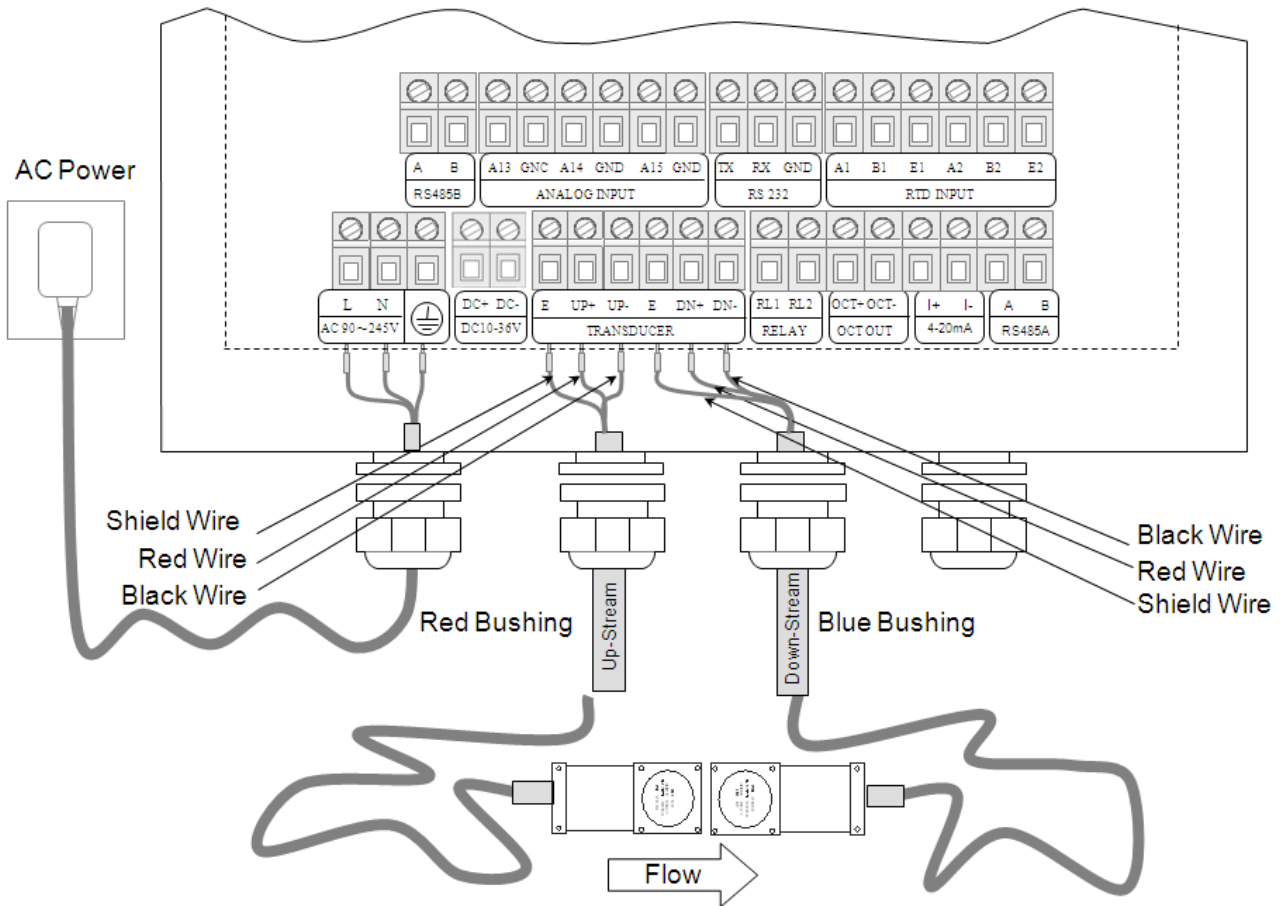

Warning

Ensure Power is Off when wiring .Ensure the instrument is correctly Earthed.

1.2 Powering On

When the meter is powered on, it will start with the following screen, the Version Number Ver:1.01 will be shown at the bottom right corner.



If it is the first time of use or an installation on a new site, the customer needs to input the new installation site parameters. Any parameters which are set by the user will be saved permanently until they are changed by the user.

When the user modifies the parameters or removes the transducers, the meter will recalculate automatically, and operate normally with the newly set parameters.

1.3 Keypad

Ultrasonic Flowmeter and Analyzer Keypad are shown as below:

cal. 0, sound vel. 9, and time . Input Numbers or Menu Code. zero < Backspace or delete characters to the left. ^ and v Return to the last menu or open the next menu.

Press Setting to enter the setup menu interface for parameters setting, all parameters will be set in this interface.

Press Enter to enter / confirm the selected item; Press Data to enter the TF card memory interface.

Velocity, Rate, Totalizer, Data, Signal, Setting, Diag. are shortcuts menus for Curve Velocity, Flow Rate, Totalizer, Data is stored, Signal Strength and Quality, Setting and System Error Codes.

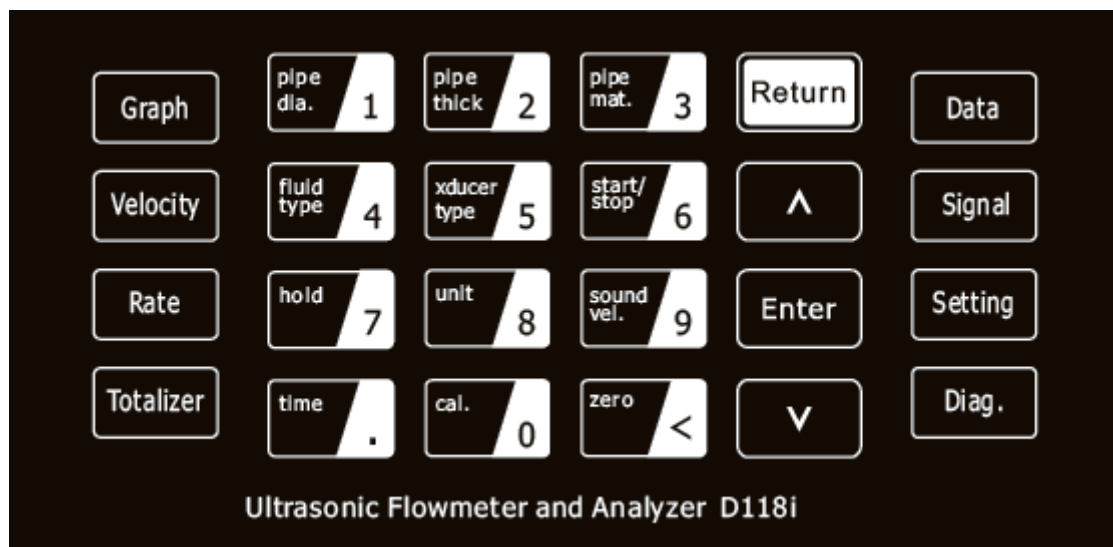

1.4 Keypad Operation

This Flowmeter and Analyzer use a window software style design. All parameter settings shall be done through the menu. Choose the item or scroll the screen by pressing the up and down button, press **Enter** to choose the corresponding operation item or to enter the setting window. Press **Return** to return to the previous menu.

For Example:

1.Data Input:

Initial setup	
01.Pipe Outer Perimeter	628.32mm
02.Pipe Outer Diameter	200.00mm
03.Pipe Wall Thickness	6.00mm
04.Pipe Inner Diameter	188.00mm
05.Pipe Material	0. Carbon Steel
06.Pipe Sound Velocity	3230.00m/s
07.Liner Material	0. None,Liner
08.Liner Sound Velocity	0.0m/s
09.Liner Thickness	0.0mm
10.Fluid Type	0.Water

UP&DOWN : Choose,->:Return previous menu,->:Enter next menu,Enter:OK

When the cursor displays at the Outer Diameter, press **Enter** to enter the Outer Diameter Input Interface. (When you press **Enter** and exit the input mode, the cursor's function will be back to normal.) Input the outer diameter of the pipe being measured, press **time** for the decimal point, press **zero** to delete the previous input data. Press **Enter** to confirm the data of the outer diameter, exit the input mode and save the current input outer diameter data. Move the cursor for other corresponding settings.

2. Option Selection

Initial setup	
01.Pipe Outer Perimeter	>0. Carbon Steel
02.Pipe Outer Diameter	1. Stainless Steel
03.Pipe Wall Thickness	2. Cast Iron
04.Pipe Inner Diameter	3. Ductile Iron
05.Pipe Material	4. Copper
06.Pipe Sound Velocity	5. PVC
07.Liner Material	6. Aluminum
08.Liner Sound Velocity	7. Asbestos
09.Liner Thickness	8. FiberGlass_Epoxy
10.Fluid Type	9. Other

UP&DOWN : Choose,->:Return previous menu,->:Enter next menu,Enter:OK

When the cursor displays at the Pipe Material, press **Enter** to enter the Pipe Material Selection Interface. Press **^** and **v** to move the cursor, when the symbol ">" points to the being measured pipe material, press **Enter** for confirmation. The system will automatically save and calculate the relevant parameters.

1.5 Flowmeter and Analyzer Window Descriptions

These windows are assigned as follows:

Flow Totalizer Display: to display Flow Rate, Totalizer, etc.

Initial Parameter Setup: to enter Pipe Outer Diameter, Pipe Wall Thickness, Fluid Type , Transducer Mounting Method, Transducer Spacing, etc.

Flow Units Options: To select the flow unit such as cubic meter, liter or other units. Turn totalizers on or off .

Setup Options: Set Zero , Scale Factor , Segment Correction, Network IDN. etc.

Input and Output Setup: CL Mode Selection, CL 4mA/20mA Output Value, LCD Back-lit Control, OCT Output Setup , Relay Output Setup, Beeper Setup, etc.

Diagnoses: Signal Strength and Quality, TOM/TOS*100.Fluid Sound Velocity , Total Time and Delta Time, Reynolds Number and Factor etc.

Appendix:. Total Working Hours, Last Power Off Time, Last Power Off Flow Rate, ON/OFF Times, Adjust AI and Adjust 4-20mA.

2. The Quick Setup Description

2.1 The Quick Setup Instructions

After installing the flowmeter according to the above mentioned requirements, the meter can start to measure flow with a simple quick setup. For example, lets say we have a DN200 pipe, Wall Thickness is 6mm, measuring Water, Pipe Material is Carbon Steel with no liner and the transducer mounting method is V-method. These parameters should be entered as follows:

Step 1. Pipe Outer Diameter:

Press  to enter the menu, select M2.02, and press  to input the pipe outer diameter, and then press  to confirm and save.

Initial setup	
01.Pipe Outer Perimeter	628.32mm
02.Pipe Outer Diameter	200.00mm
03.Pipe Wall Thickness	6.00mm
04.Pipe Inner Diameter	188.00mm
05.Pipe Material	0. Carbon Steel
06.Pipe Sound Velocity	3230.00m/s
07.Liner Material	0. None,Liner
08.Liner Sound Velocity	0.0m/s
09.Liner Thickness	0.0mm
10.Fluid Type	0.Water

UP&DOWN: Choose,->:Return previous menu,-<:Enter next menu,Enter:OK

Step 2. Pipe Wall Thickness

Press  to enter the menu, select M2.03, and press  to input the pipe wall thickness, and press  to confirm and save.

Initial setup	
01.Pipe Outer Perimeter	628.32mm
02.Pipe Outer Diameter	200.00mm
03.Pipe Wall Thickness	6.00mm
04.Pipe Inner Diameter	188.00mm
05.Pipe Material	0. Carbon Steel
06.Pipe Sound Velocity	3230.00m/s
07.Liner Material	0. None,Liner
08.Liner Sound Velocity	0.0m/s
09.Liner Thickness	0.0mm
10.Fluid Type	0.Water

UP&DOWN: Choose,<--:Return previous menu,->:Enter next menu,Enter:OK

Step 3. Pipe Material

Press **Setting** to enter the menu, select M2.05, press **Enter**, press **^** or **v** to select the Pipe Material, and press **Enter** for confirmation.

Initial setup	
01.Pipe Outer Perimeter	628.32mm
02.Pipe Outer Diameter	200.00mm
03.Pipe Wall Thickness	6.00mm
04.Pipe Inner Diameter	188.00mm
05.Pipe Material	0. Carbon Steel
06.Pipe Sound Velocity	3230.00m/s
07.Liner Material	0. None,Liner
08.Liner Sound Velocity	0.0m/s
09.Liner Thickness	0.0mm
10.Fluid Type	0.Water

UP&DOWN: Choose,<--:Return previous menu,->:Enter next menu,Enter:OK

Step 4: Pipe Liner Parameters (It includes the Liner Thickness and Liner Material Sound Velocity)

Press **Setting** to enter the menu, select M2.07, press **Enter**, press **^** or **v** to select Pipe Liner Material, and press **Enter** for confirmation..

Initial setup	
01.Pipe Outer Perimeter	628.32mm
02.Pipe Outer Diameter	200.00mm
03.Pipe Wall Thickness	6.00mm
04.Pipe Inner Diameter	188.00mm
05.Pipe Material	0. Carbon Steel
06.Pipe Sound Velocity	3230.00m/s
07.Liner Material	0. None,Liner
08.Liner Sound Velocity	0.0m/s
09.Liner Thickness	0.0mm
10.Fluid Type	0.Water

UP&DOWN: Choose,<--:Return previous menu,->:Enter next menu,Enter:OK

Step 5. Fluid Type

Press **Setting** to enter the menu, select M2.10, press **Enter**, press **^** or **v** to select the Fluid Type, and

press **Enter** for confirmation..

Initial setup	
01.Pipe Outer Perimeter	628.32mm
02.Pipe Outer Diameter	200.00mm
03.Pipe Wall Thickness	6.00mm
04.Pipe Inner Diameter	188.00mm
05.Pipe Material	0. Carbon Steel
06.Pipe Sound Velocity	3230.00m/s
07.Liner Material	0. None,Liner
08.Liner Sound Velocity	0.0m/s
09.Liner Thickness	0.0mm
10.Fluid Type	0.Water

UP&DOWN: Choose,<--:Return previous menu,->:Enter next menu,Enter:OK

Step 6. Transducer Type

Press **Setting** to enter the menu, select M2.13, press **Enter**, press **^** or **v** to select the Transducer Type, and press **Enter** for confirmation..

Initial setup	
11.Fluid Sound Velocity	1482. 00m/s
12.Fluid Viscosity	1. 0038cST
13. Transducer Type	0. Standard
14. Transducer Mounting	0. V
15. Transducer Spacing	77. 37mm
16. Parameter Setup	Entry To SAVE
17. Cross-sectional Area	11305. 96mm
18. WiFi Setup	1. Ap

UP&DOWN: Choose,<--:Return previous menu,->:Enter next menu,Enter:OK

Step 7. Transducer Mounting Methods

Press **Setting** to enter the menu, select M2.14, press **Enter**, press **^** or **v** to select the Transducer Mounting Methods, and press **Enter** for confirmation.

Initial setup	
11.Fluid Sound Velocity	1482. 00m/s
12.Fluid Viscosity	1. 0038cST
13. Transducer Type	0. Standard
14. Transducer Mounting	0. V
15. Transducer Spacing	77. 37mm
16. Parameter Setup	Entry To SAVE
17. Cross-sectional Area	11305. 96mm
18. WiFi Setup	1. Ap

UP&DOWN: Choose,<--:Return previous menu,->:Enter next menu,Enter:OK

Step 8. Adjust the Transducer Spacing

Press **Setting** to enter the menu, refer to M2.15, accurately install the transducer according to the displayed transducer mounting spacing and the selected mounting method. (See Chapter One: Installation)

GENTOS		2015-07-01 10:04:43
Initial setup		
11.Fluid Sound Velocity		1482.00m/s
12.Fluid Viscosity		1.0038cST
13.Transducer Type		0.Standard
14.Transducer Mounting		0.V
15.Transducer Spacing		160.18mm
16.Parameter Setup		Entry To SAVE
17.Cross-sectional Area		11305.96mm
18.Wifi Setup		1.Ap

UP&DOWN: Choose,<-:Return previous menu,->:Enter next menu,Enter:OK

Step 9. Flow Rate

Press **Rate** to enter the Flow Rate Interface, large font displays the flow rate, small font displays the Positive Totalizer and the Negative Totalizer, the coordinate displays the Real-time Flow Velocity.

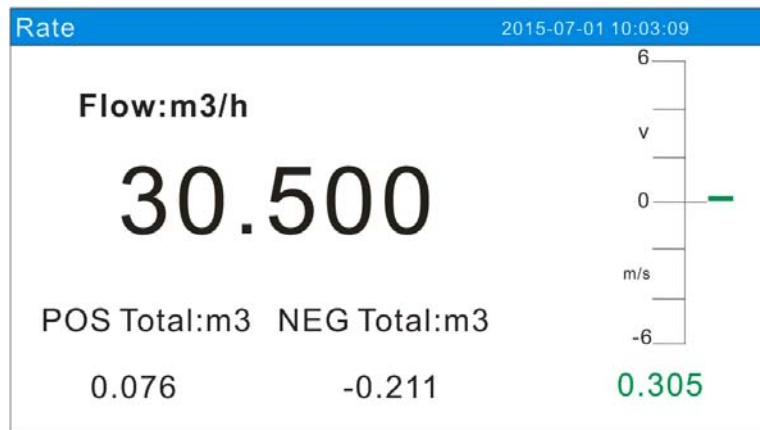

2.2 The Shortcut Menu Descriptions

Press **Graph** to enter the Normal Curve Interface. Press **Graph** to cycle between the normal mode and the dynamic mode;

press **^** or **v** to switch the Instantaneous Flow Rate or Flow Velocity Curve; press **Enter** to pause or continue to check the wave curve.

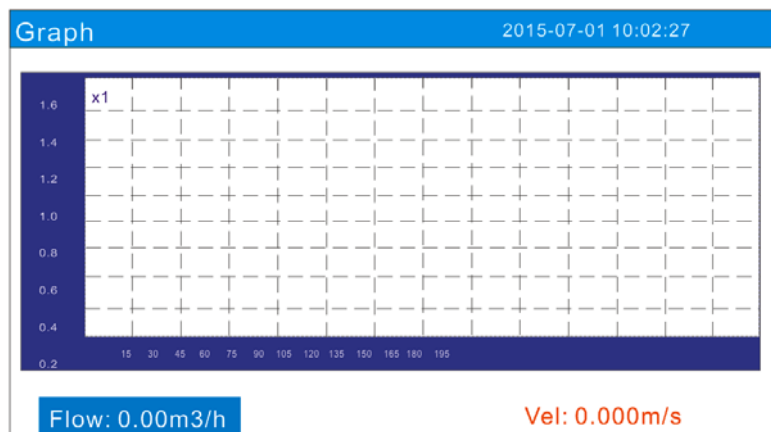

Press **Velocity**

Large font displays the Flow Velocity, small font displays the Positive Totalizer and Negative Totalizer, the coordinate displays the Real-time Flow Rate.

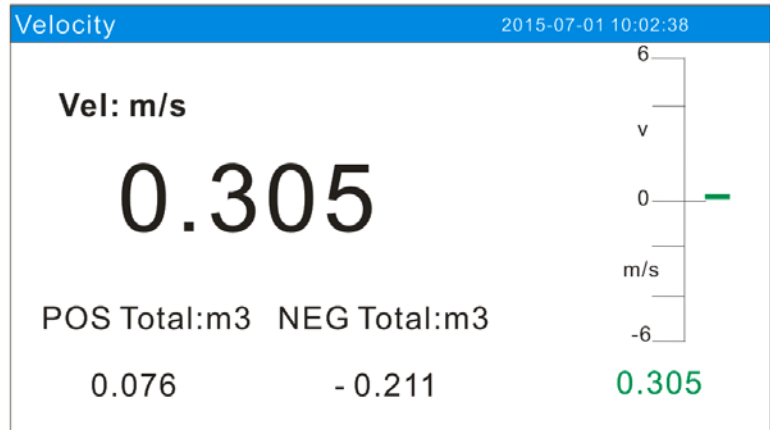

Press **Rate**

Large font displays the Flow Rate, small font displays the Positive Totalizer and Negative Totalizer, the coordinate displays the Real-time Flow Rate.

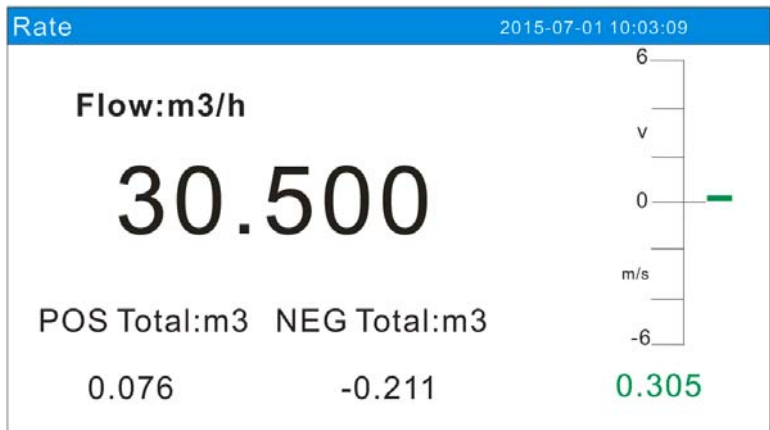

Press **Totalizer**

Large font displays the Totalizer Flow, By pressing the up and down keys to switch the Positive Totalizer, Negative Totalizer, the Net Totalizer as the large font display.

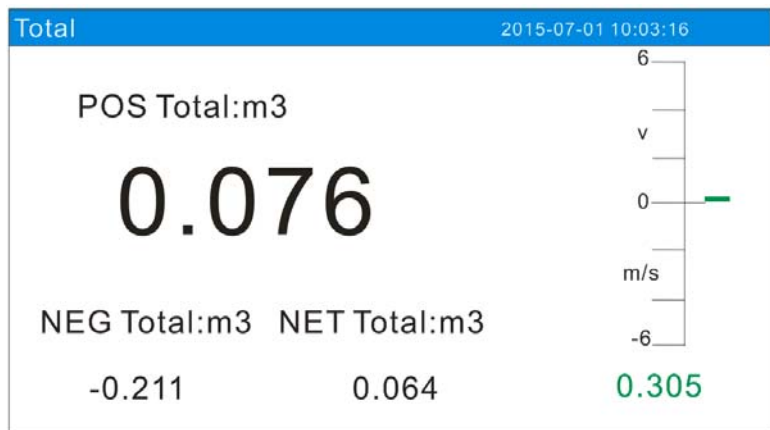

Press **Data**

Enter to Data Collection Interface. To modify the data collection time interval in this interface.

Data
2015-07-01 10:03:33

Data Collection

File Name: 20150701 .txt

Interval Time: 2 sec

start

Press **Signal**

Large font displays the Signal Quality, small font displays the Signal Strength of the upstream and downstream, the coordinate displays the Real-time Flow Rate..

Signal
2015-07-01 10:03:38

Quality

99

Strength Up Strength Down

67.6 67.6

0.000
m/s

Press **Diag.**

Large Font displays the Current System Status, small font displays the Signal Strength and Signal Quality of upstream and downstream, the coordinate displays the Real-time Flow Rate.

Diagnostics
2015-07-01 10:03:54

State

Instrument Working Properly

Strength Up 67.6

Strength Down 67.6

Quality 99

0.000
m/s

Press  1
 Enter M2.02 for Pipe Outer Diameter setting.

Initial setup	
01.Pipe Outer Perimeter	628.32mm
02.Pipe Outer Diameter	200.00mm
03.Pipe Wall Thickness	6.00mm
04.Pipe Inner Diameter	188.00mm
05.Pipe Material	0. Carbon Steel
06.Pipe Sound Velocity	3230.00m/s
07.Liner Material	0. None,Liner
08.Liner Sound Velocity	0.0m/s
09.Liner Thickness	0.0mm
10.Fluid Type	0.Water

UP&DOWN : Choose,<-:Return previous menu,->:Enter next menu,Enter:OK

Press  2
 Enter M2.03 for Pipe Wall Thickness setting.

Initial setup	
01.Pipe Outer Perimeter	628.32mm
02.Pipe Outer Diameter	200.00mm
03.Pipe Wall Thickness	6.00mm
04.Pipe Inner Diameter	188.00mm
05.Pipe Material	0. Carbon Steel
06.Pipe Sound Velocity	3230.00m/s
07.Liner Material	0. None,Liner
08.Liner Sound Velocity	0.0m/s
09.Liner Thickness	0.0mm
10.Fluid Type	0.Water

UP&DOWN : Choose,<-:Return previous menu,->:Enter next menu,Enter:OK

Press  3
 Enter M2.05 for Pipe Material setting.

Initial setup	
01.Pipe Outer Perimeter	628.32mm
02.Pipe Outer Diameter	200.00mm
03.Pipe Wall Thickness	6.00mm
04.Pipe Inner Diameter	188.00mm
05.Pipe Material	0. Carbon Steel
06.Pipe Sound Velocity	3230.00m/s
07.Liner Material	0. None,Liner
08.Liner Sound Velocity	0.0m/s
09.Liner Thickness	0.0mm
10.Fluid Type	0.Water

UP&DOWN : Choose,<-:Return previous menu,->:Enter next menu,Enter:OK



Press

Enter M2.10 for Fluid Type option.

GENTOS		2015-07-01 10:04:43
Initial setup		
01.Pipe Outer Perimeter		628.32mm
02.Pipe Outer Diameter		200.00mm
03.Pipe Wall Thickness		0.01mm
04.Pipe Inner Diameter		188.00mm
05.Pipe Material		0. Carbon Steel
06.Pipe Sound Velocity		3230.00m/s
07.Liner Material		0. None,Liner
08.Liner Sound Velocity		0.0m/s
09.Liner Thickness		0.0mm
10.Fluid Type		0.Water

UP&DOWN : Choose,<--:Return previous menu,->:Enter next menu,Enter:OK



Press

Enter M2.13 for Transducer Type option.

GENTOS		2015-07-01 10:04:43
Initial setup		
11.Fluid Sound Velocity		1482. 00m/s
12.Fluid Viscosity		1. 0038cST
13.Transducer Type		0.Standard
14.Transducer Mounting		0. V
15.Transducer Spacing		160.18mm
16.Parameter Setup		Entry To SAVE
17.Cross-sectional Area		11305. 96mm
18.Wifi Setup		1. Ap



UP&DOWN : Choose,<--:Return previous menu,->:Enter next menu,Enter:OK





Press

Manual Input Net Totalizer.

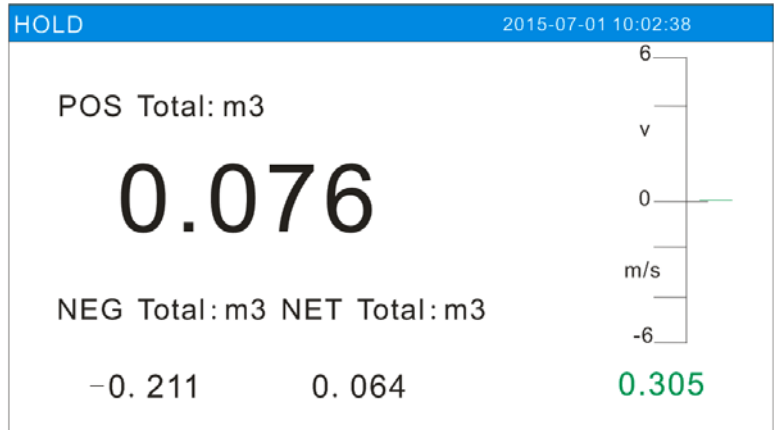

Press  Large interface remains the Current Totalizer, press  to refresh the value of the Totalizer ,press  again to suspend refreshing the Totalizer value, keep the current Totalizer value.



Press  Enter M3.02 for Flow Rate Units option.

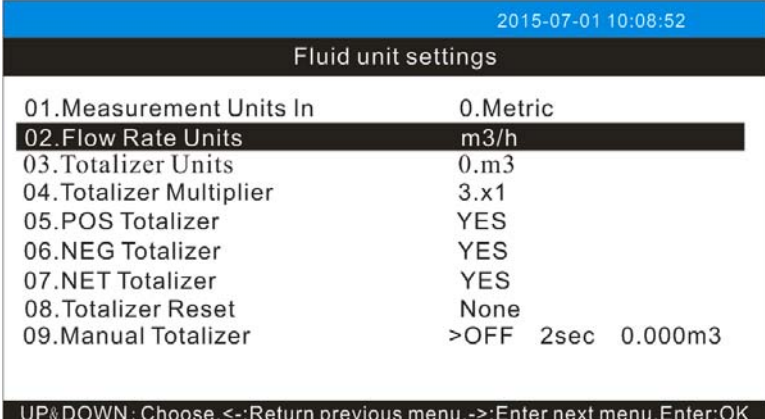

The screenshot shows the 'Fluid unit settings' menu with a timestamp of 2015-07-01 10:08:52. The menu items are as follows:

01.Measurement Units In	0.Metric
02.Flow Rate Units	m3/h
03.Totalizer Units	0.m3
04.Totalizer Multiplier	3.x1
05.POS Totalizer	YES
06.NEG Totalizer	YES
07.NET Totalizer	YES
08.Totalizer Reset	None
09.Manual Totalizer	>OFF 2sec 0.000m3

UP&DOWN: Choose, <-:Return previous menu, ->:Enter next menu,Enter:OK

Press  Enter M6.03 for Fluid Sound Velocity.

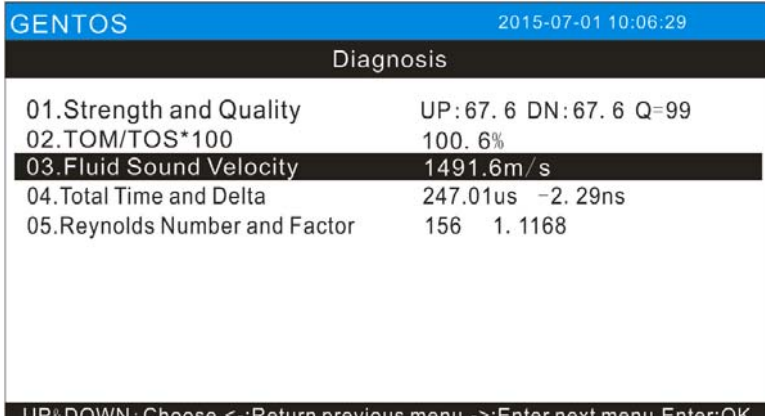



The screenshot shows the 'GENTOS Diagnosis' screen with a timestamp of 2015-07-01 10:06:29. The menu items are as follows:



01.Strength and Quality	UP: 67.6 DN: 67.6 Q=99
02.TOM/TOS*100	100.6%
03.Fluid Sound Velocity	1491.6m/s
04.Total Time and Delta	247.01us -2.29ns
05.Reynolds Number and Factor	156 1.1168

UP&DOWN: Choose, <-:Return previous menu, ->:Enter next menu,Enter:OK



Press  Enter the Large Interface for Manual Factor Correction.

Press  to start the Manual Net Totalizer, compare with the Totalizer Value of the Standard Meter at the same period.

Press  to input the Net Totalizer Value of the Standard Meter, press  for confirmation. If the ratio is between 0.5-1.5, then the K factor correction is successful, if not, there is correction error.

Press  to exit the Correction Mode.



Press  Enter M5.09 to set the date and time.

GENTOS 2015-01-01 00:05:50

Input and output settings

01.AI1 Value	-12. 51
02.AI2 Value	-12. 49
03.AI3 Value	-12. 50
04.CL Mode Select	0. 4-20mA vs Flow
05.CL 4mA Output Value	0.0000m3/h
06.CL 20mA Output Value	14400. 00m3/h
07.CL Check	Press ENT When Ready
08.CL Current Output	4.000mA
09.YY-MM-DDHH:MM:SS	15-01-01 00:01:40
10.Ultrasonic Flowmeter S/N	S/N=20000000

UP&DOWN : Choose, <-:Return previous menu,->:Enter next menu,Enter:OK



Press  Enter M4.03 to set Zero.

GENTOS 2015-07-01 10:07:43

Select setting

01.Damping	10sec
02.Low Flow Cutoff Velocity	0.030m/s
03.Set Zero	>Press Enter to go
04.Reset Zero	NO
05.Manual Zero Point	0.000m3/h
06.Scale Factor	1.0000
07.Network IDN	88
08.System Lock	Unlocked
09.Segment Correction	NO
10.Segment Factor	Entry

UP&DOWN : Choose, <-:Return previous menu,->:Enter next menu,Enter:OK



Attention

Dual-function keys are available for the shortcut menu of the first and second grade of menu setting, but they are invalid under the data input status.

2.3 Setup Menu Description

Press 

Enter the Main Menu Setting Interface..

2015-07-01 10:03:48	
Main Menu	
01.Main data display	
02.Initial setup	
03.Fluid unit setting	
04.Select settings	
05.The input and output settings	
06.Diagnosis	
07.Appendix	
UP&DOWN : Choose,->:Return previous menu,-<:Enter next menu,Enter:OK	

01.Flow/Total Display

Examine the Date time ,Flow Rate, Flow Totalizer and Net Total Today, etc.

2015-07-01 10:06:13	
Flow/Today display	
01.Flow /Net	2231x1 m3
02.Flow /Vel	5. 816m/s
03.Flow /POS	2231x1 m3
04.Flow /NEG	0x1 m3
05.Date Time/Flow	415. 622m3/h
06.Net Total Today	1360. 912m3
UP&DOWN : Choose,->:Return previous menu,-<:Enter next menu,Enter:OK	

02.Initial Settings

Initial Parameters Setting Interface, including the pipe size, pipe material, measured fluid and sound velocity, etc.

2015-07-01 10:04:43	
Initial setup	
01.Pipe Outer Perimeter	628.32mm
02.Pipe Outer Diameter	200.00mm
03.Pipe Wall Thickness	6.00mm
04.Pipe Inner Diameter	188.00mm
05.Pipe Material	0. Carbon Steel
06.Pipe Sound Velocity	2424.00m/s
07.Liner Material	0. None,Liner
08.Liner Sound Velocity	0.0m/s
09.Liner Thickness	0.0mm
10.Fluid Type	0.Water
UP&DOWN : Choose,->:Return previous menu,-<:Enter next menu,Enter:OK	

03.Fluid Unit Settings

To set the flow unit, totalizer on-off, reset the totalizer ,factory reset, etc.

GENTOS		2015-07-01 10:08:52	
Fluid unit settings			
01.Measurement Units		0.Metric	
02.Flow Rate Units		m3/h	
03.Totalizer Units		0.m3	
04.Totalizer Multiplier		3.x1	
05.POS Totalizer		YES	
06.NEG Totalizer		YES	
07.NET Totalizer		YES	
08.Totalizer Reset		None	
09.Manual Totalizer		>OFF	2sec 0.000m3

UP&DOWN : Choose,<-:Return previous menu,->:Enter next menu,Enter:OK

04. Select Settings

To set the Damping, Zero and Reset, Manual Zero Offset, Network IDN and Segment Correction.

GENTOS		2015-07-01 10:07:43	
Select setting			
01.Damping		10sec	
02.Low Flow Cutoff Velocity		0.030m/s	
03.Set Zero		>Press Enter to go	
04.Reset Zero		NO	
05.Manual Zero Point		0.000m3/h	
06.Scale Factor		1.0000	
07.Network IDN		88	
08.System Lock		Unlocked	
09.Segment Correction		NO	
10.Segment Factor		Entry	

UP&DOWN : Choose,<-:Return previous menu,->:Enter next menu,Enter:OK

05. Input and Output Settings

To examine and set the AI Input, OCT Output, 4-20mA Output, Relay Output, Beeper Output, Date and Time, etc

GENTOS		2015-07-01 10:05:50	
Input and output settings			
01.AI1 Value		-12.51	
02.AI2 Value		-12.49	
03.AI3 Value		-12.50	
04.CL Mode Select		0. 4-20mA vs Flow	
05.CL 4mA Output Value		0.0000m3/h	
06.CL 20mA Output Value		400.0000m3/h	
07.CL Check		Press ENT When Ready	
08.CL Current Output		4.000mA	
09.YY-MM-DDHH:MM:SS		15-07-01 10:05:50	
10.Ultrasonic Flowmeter S/N		S/N=50003270	

UP&DOWN : Choose,<-:Return previous menu,->:Enter next menu,Enter:OK

06. Diagnosis

Enter the Diagnosis Interface. To examine the Signal Strength and Signal Quality, TOM/TOS*100, Total Transit Time and Delta Time, Reynolds Factor.

GENTOS		2015-07-01 10:06:29
Diagnosis		
01.Strength and Quality	UP: 67.6	DN: 67.6 Q=99
02.TOM/TOS*100	100.6%	
03.Fluid Sound Velocity	1491.6m/s	
04.Total Time and Delta	247.01us -2.29ns	
05.Reynolds Number and Factor	156	1.168

UP&DOWN : Choose,<:-:Return previous menu,->:Enter next menu,Enter:OK

07. Appendix

To examine the ON/OFF Time, Total Working Hours, Last Power Off Time , Last Flow Rate, ON/OFF Times, Adjust AI and adjust 4-20mA.

Appendix		2015-07-01 10:06:42
01. ON/OFF Time	Press ENT When Ready	
02.Total Working Hours	00067:28:57	
03.Last Power Off Time	15-06-21 10:04:52	
04.Last Flow Rate	10.500m ³ /h	
05.ON/OFF Times	66	
06.Adjust AI	Press ENT When Ready	
07.Adjust 4-20mA	>4mA	



>Enter next menu,<-return fore menu,Enter:OK

2.4 Measurement Site Selection

Compared with other kinds of flowmeters, Ultrasonic Flowmeter is the simplest one to install. Choose a proper measurement site, enter the pipe's parameters into the flowmeter. Install and fix the transducers on the pipe as instructed by the meter and start the measurement.

When selecting a measurement site, it is important to select an area where the fluid flow profile is fully developed to guarantee a highly accurate measurement. Use the following guidelines to select a proper installation site:

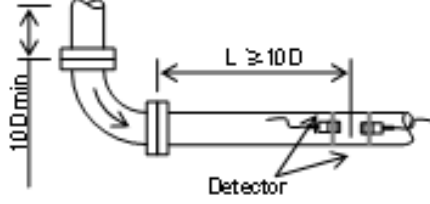
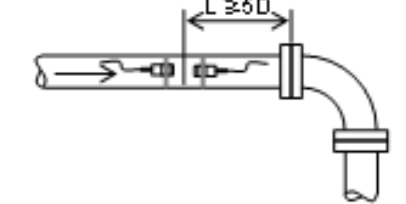
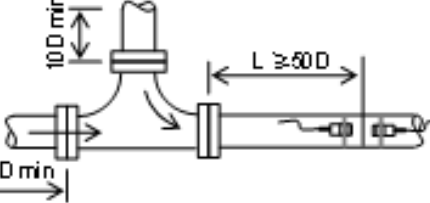
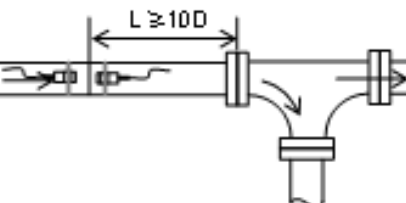
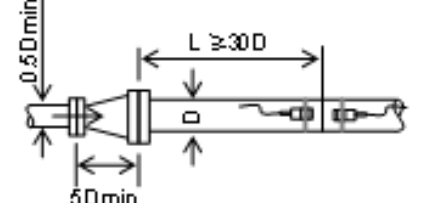
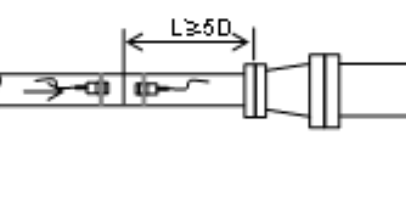
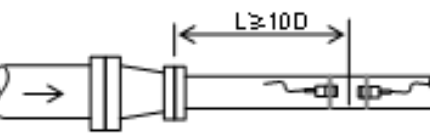
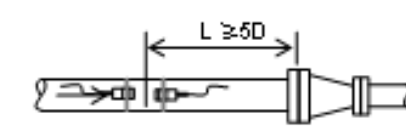
- Choose a section of pipe that is always full of liquid, such as a vertical pipe with flow in the upward direction or a full horizontal pipe.
- Ensure enough straight pipe length at least equal to the figure shown below for the upstream and downstream transducers installation.
- On the horizontal pipe, the transducer should be mounted on the 3 o'clock and 9 o'clock position of the pipe section, avoid the 6 o'clock and 12 o'clock position, in order to avoid the signal attenuation caused by the sediment at the bottom, or air bubbles or cavitation.
- Ensure that the pipe surface temperature at the measuring point is within the transducer temperature limits.
- Consider the inside condition of the pipe carefully. If possible, select a section of pipe where the inside is free of excessive corrosion or scaling.
- Choose a section of sound conducting pipe.

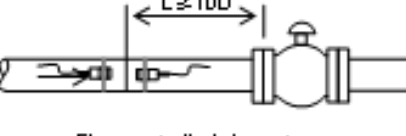
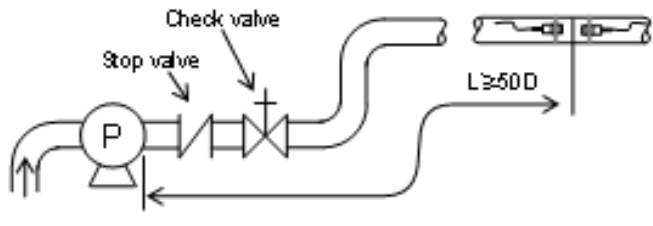
Name	Straight length of upstream piping	Straight length of downstream piping
90° bend		
Tee		
Diffuser		
Reduce		
Valve	 <p style="text-align: center;">Flow controlled upstream</p>	 <p style="text-align: center;">Flow controlled downstream</p>
Pump		

3. Transducer Installation

3.1 Installing the Transducer

Before installing the transducers, clean the pipe surface where the transducers are to be mounted. Remove any rust, scale or loose paint and make a smooth surface. Choose a section of sound conducting pipe for installing the transducers. Apply a wide band of sonic coupling compound down the center of the face of each transducer as well as on the pipe surface, ensure there are no air bubbles between the transducers and the pipe wall, and then attach the transducers to the pipe with the straps provided and tighten them securely.

Note:

1. The two transducers should be mounted at the pipe's centerline on horizontal pipes. Make sure that the transducer mounting direction is parallel with the flow.
2. During the installation, there should be no air bubbles or particles between the transducer and the pipe wall. On horizontal pipes, the transducers should be mounted in the 3 o'clock and 9 o'clock positions of the pipe section in order to avoid any air bubbles inside the top portion of the pipe.
3. Refer to 2.15 for the Transducer Mounting Spacing.
4. If the transducers cannot be mounted horizontally symmetrically due to limitation of the local installation conditions, it may be necessary to mount the transducers at a location where there is a guaranteed full pipe condition (the pipe is always full of liquid).

3.2 Transducer Mounting Methods

Three transducer mounting methods are available. They are respectively: V method, Z method and N method. The V method is primarily used on small diameter pipes (DN100~300mm, 4"~12"). The Z method is used in applications where the V method cannot work due to poor signal or no signal detected. In addition, the Z method generally works better on larger diameter pipes (over DN300mm, 12") or cast iron pipes.

The N method is an uncommonly used method. It is used on smaller diameter pipes (below DN50mm, 2").

3.2.1 V Method

The V method is considered as the standard method. It usually gives a more accurate reading and is used on pipe diameters ranging from 25mm to 400mm (1" ~ 16") approximately. Also, it is convenient to use, but still requires proper installation of the transducers, contact on the pipe at the pipe's centerline and equal spacing on either side of the centerline.

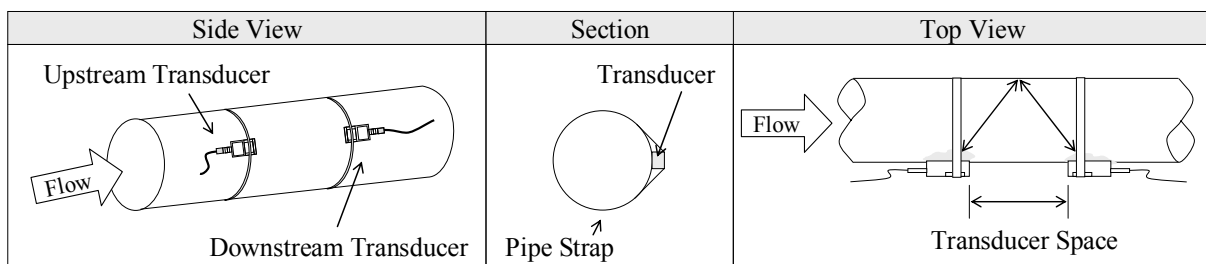

3.2.2 Z Method

The signal transmitted in a Z method installation has less attenuation than a signal transmitted with the V method when the pipes are too large, there are some suspended solid in the fluid, or the scaling and liner are too thick. This is because the Z method utilizes a directly transmitted (rather than reflected) signal which transverses the liquid only once. The Z method is able to measure on pipe diameters ranging from 100mm to 5000mm (4" to 200") approximately. Therefore, we recommend the Z method for pipe diameters over 300mm (12").

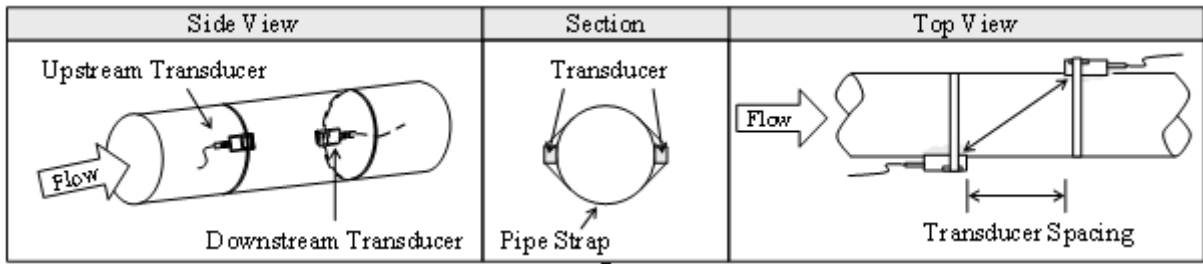

3.2.3 N Method (not commonly used)

With the N method, the sound waves traverse the fluid three times and bounce twice off the pipe walls. It is suitable for small pipe diameter measurement. The measurement accuracy can be improved by extending the transit distance with the N method (uncommonly used).

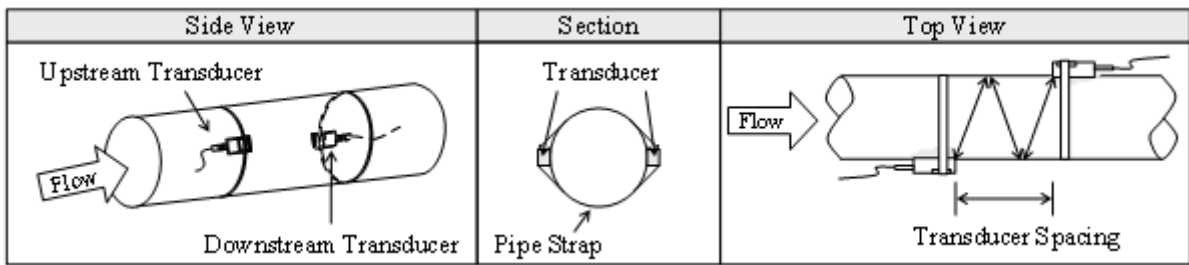

3.3 Transducer Installation and Fixing

3.3.1 Transducer Pipe Hoop Installation

1. Determine the transducers installation position and the spacing, and clean the pipe surface (refer to the Instructions Manual on Installation Position, Installation Spacing and the Measurement Point Option).

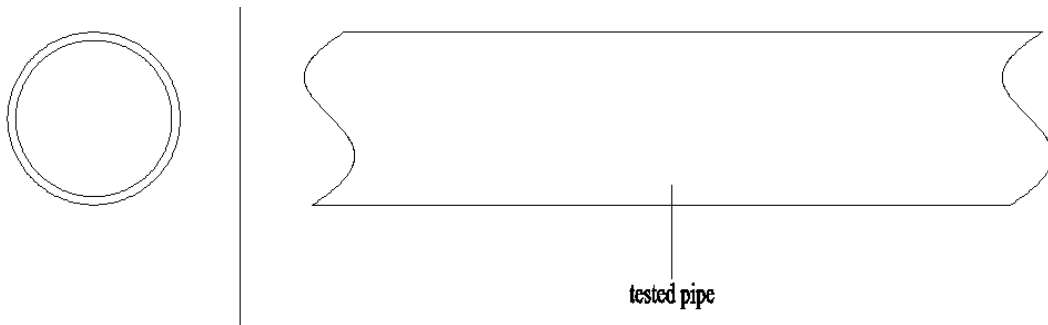

2. Apply a wide band of sonic coupling compound down the center of the face of each transducer, and attach to the pipe.(On horizontal pipes, the transducers should be mounted in the 3 o'clock and 9 o'clock positions of the pipe section in order to avoid any air bubbles inside the top portion of the pipe.)

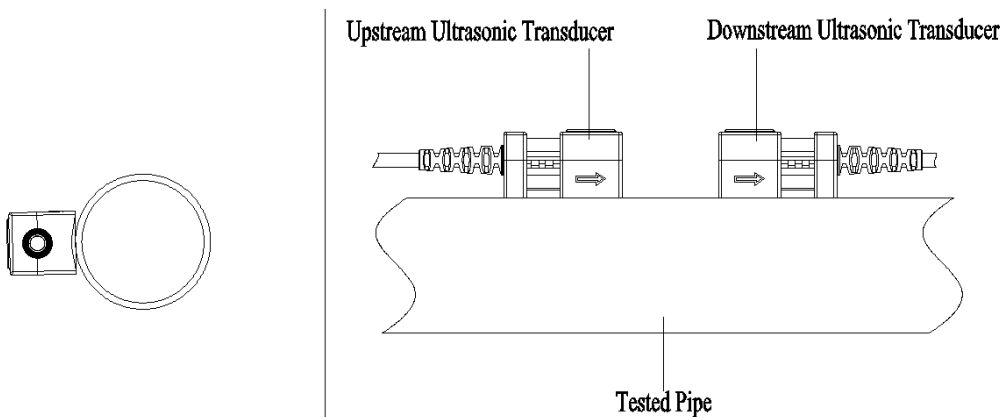

3. Choose either Position A or Position B, then use pipe hoop to bolt the lock screw. (On horizontal pipes, the transducers should be mounted in the 3 o'clock and 9 o'clock positions of the pipe section in order to avoid any

air bubbles inside the top portion of the pipe.)

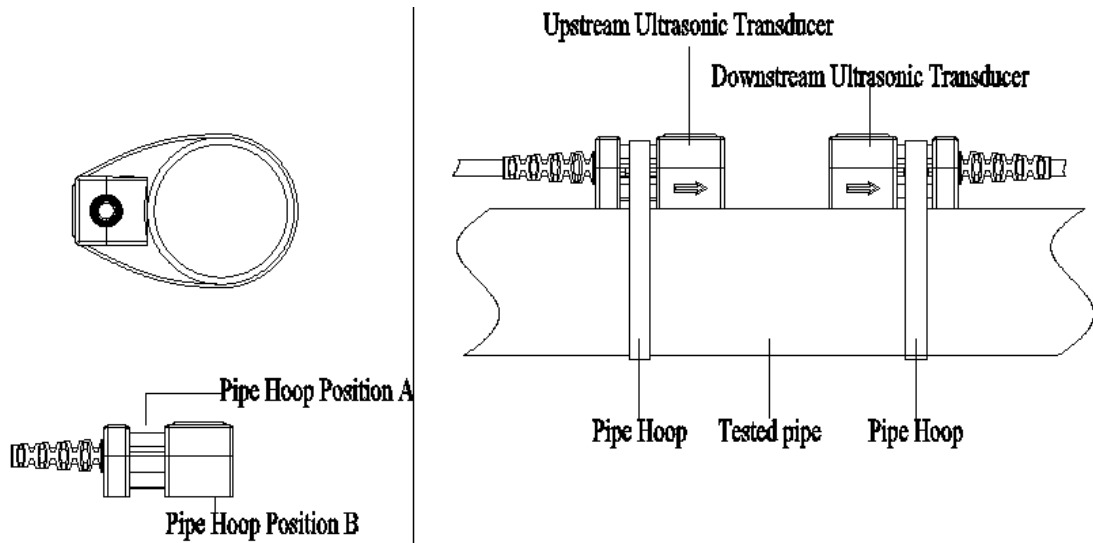

3.3.2 Transducer Cable Ties Installation

1. Determine the transducer installation position and the spacing, clean the pipe hoop, bend the pipe hoop to be the same size as the pipe's outer diameter and stick onto the pipe. (Refer to the Instruction Manual for the Installation Position, Installation Spacing and the Measurement Point option. On horizontal pipes, the transducers should be mounted in the 3 o'clock and 9 o'clock positions of the pipe section in order to avoid any air bubbles inside the top portion of the pipe.)

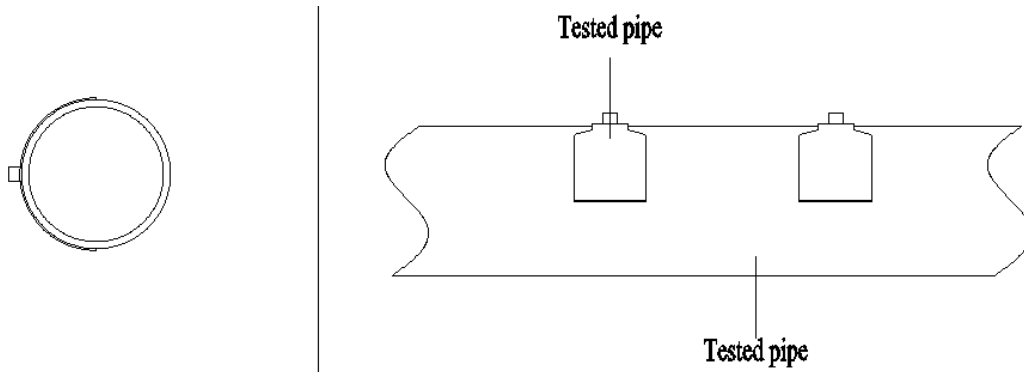

2. Screw the Lower Shell to the pipe hoop and strictly fasten it to the pipeline. (On horizontal pipes, the transducers should be mounted in the 3 o'clock and 9 o'clock positions of the pipe section in order to avoid any air bubbles inside the top portion of the pipe.)

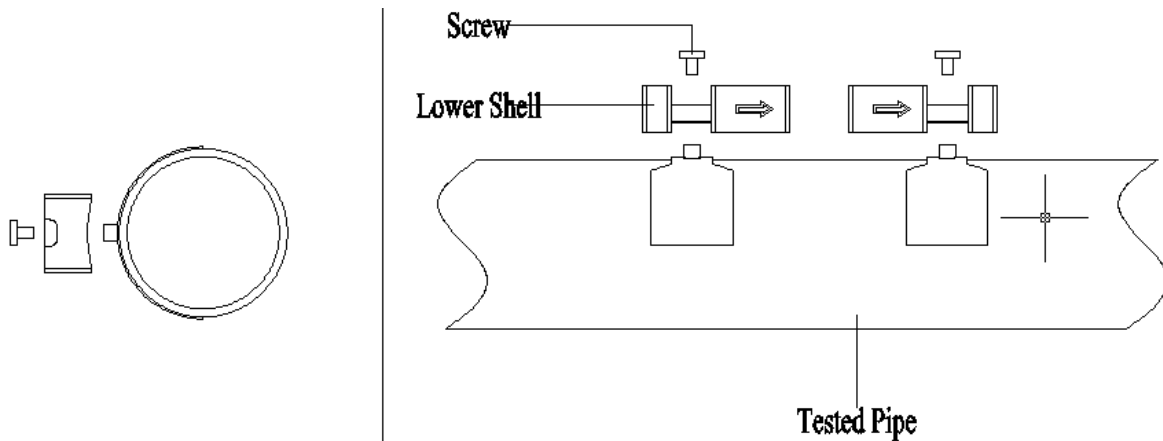

3. Assemble the transducer into the Lower Shell, and then lock the upper cover and the lower shell. (The upper cover is equipped with the anti-disengaging SHCS. On horizontal pipes, the transducers should be mounted in the

3 o'clock and 9 o'clock positions of the pipe section in order to avoid any air bubbles inside the top portion of the pipe.)

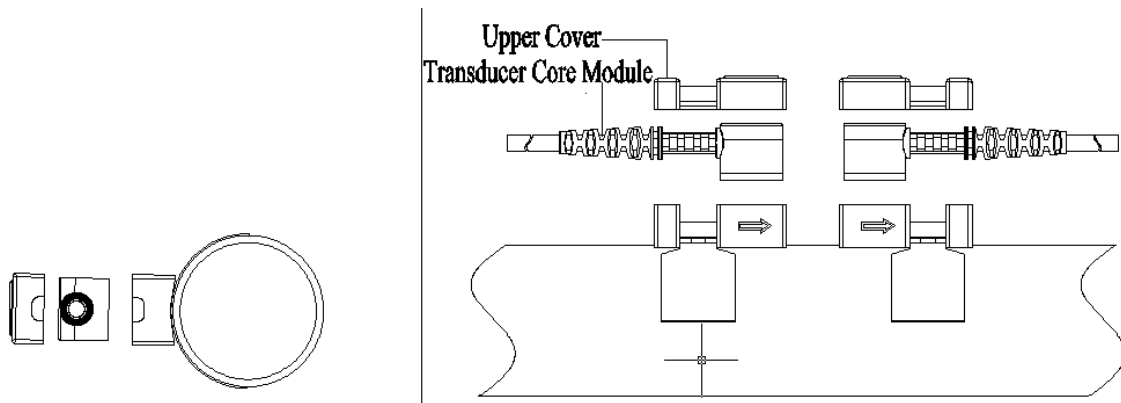

4. The figure below shows a schematic after assembly (On horizontal pipes, the transducers should be mounted in the 3 o'clock and 9 o'clock positions of the pipe section in order to avoid any air bubbles inside the top portion of the pipe.)

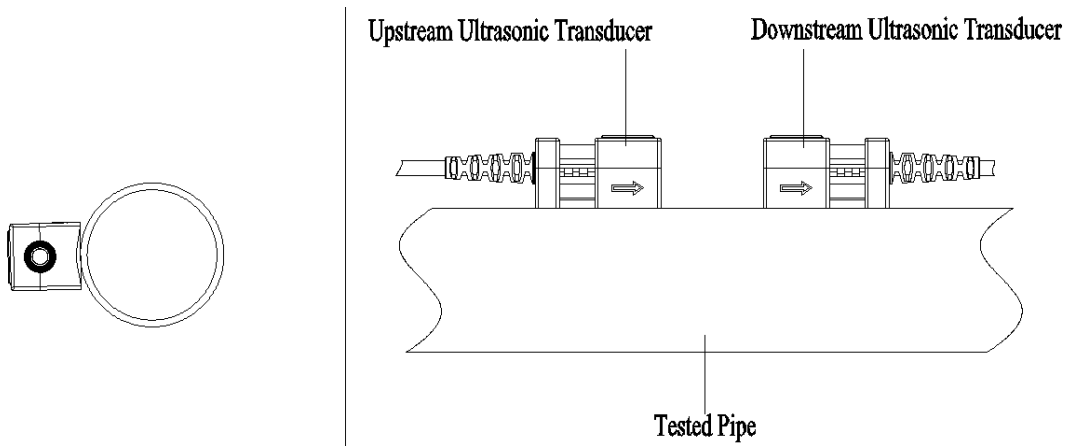

5. Exploded views of transducer cable ties installation:

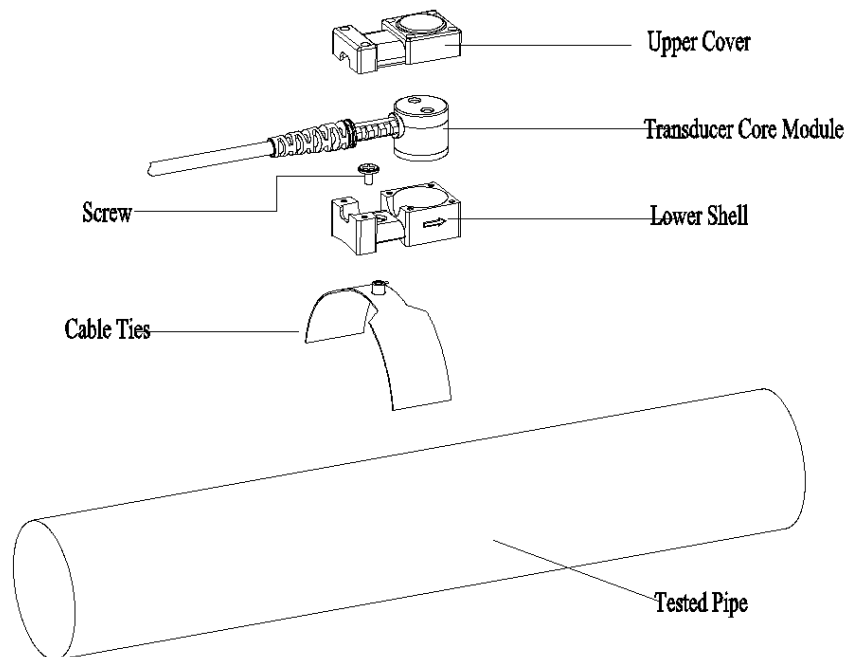

3.4 Transducer Mounting Inspection

Confirm the transducer is installed properly by checking the detected signal strength, total transit time, delta time as well as transit time ratio Key 9.

The "mounting" condition directly influences the flow value accuracy and system long-term operation reliability. In most instances it is only necessary apply a wide band of sonic coupling compound lengthwise on the face of the transducer and stick it to the outside pipe wall to get good measurement results. However, the following checks still need to be carried out in order to ensure a high reliability of the measurement and long-term operation of the instrument.

3.4.1 Signal Strength

Signal strength (displayed in Signal) indicates a detected strength of the signal both from upstream and downstream directions. The relevant signal strength is indicated by numbers from 00.0 ~ 99.9. 00.0 represents no signal detected while 99.9 represents maximum signal strength. Normally, the stronger the signal strength detected, the better the instrument reliably will be. It will also result in a more stable the measurement value.

Ensure enough sonic coupling compound has been applied .Adjust the transducer position during the installation to obtain the maximum signal strength.

Normal system operation requires signal strength over 65.0 from both upstream and downstream directions. If the signal strength detected is too low, the transducer installation position and the transducer mounting spacing should be re-adjusted and the pipe should be re-inspected. If necessary, change the mounting method to be Z method.

3.4.2 Signal Quality (Q value)

Q value is short for Signal Quality (displayed in Signal). It indicates the level of the signal detected. Q value is indicated by numbers from 00 ~ 99. 00 represents the minimum signal detected while 99 represent the maximum. Normally, the transducer position should be adjusted repeatedly and coupling compound application should be checked frequently to ensure the signal quality can be detected as strong as possible.

3.4.3 Total Time and Delta Time

"Total Time and Delta Time", which displays in Window M6.04, indicates the condition of the installation. The measurement calculations in the flowmeter are based upon these two parameters. Therefore, when "Delta Time" fluctuates widely, so does the velocity and flow .This means that the signal quality detected is poor. It may be the resulted of poor pipe-installation conditions, inadequate transducer installation or incorrect parameter input.

Generally, "Delta Time" fluctuation should be less than $\pm 20\%$. Only when the pipe diameter is too small or velocity is too low can the fluctuation be wider.

3.4.4 Transit Time Ratio

Transit Time Ratio indicates if the transducer mounting spacing is accurate. The normal transit time ratio should be 100 ± 3 if the installation is proper. Check it in Window M9.02.

Attention

If the transit time ratio is over 100 ± 3 , it is necessary to check:

If the parameters (pipe outside diameter, wall thickness, pipe material, liner, etc.) have been entered correctly,

If the transducer mounting spacing is in accordance with the display in Window M2.15,

If the transducer is mounted at the pipe's centerline on the same diameter,

If the scale is too thick or the pipe mounting is distorted in shape, etc.



3.4.5 Warnings

- (1) Pipe parameters entered must be accurate; otherwise the flowmeter will not work properly.
- (2) During the installation, apply enough coupling compounds to the transducer to ensure adequate contact with the pipe wall. While checking the signal strength and Q value, move the transducers slowly around the mounting site until the strongest signal and maximum Q value can be obtained. .
- (3) Check to be sure the mounting spacing is accordance with the display in Window M2.15 and the

- transducer is mounted at the pipe's centerline on the same diameter.
- (4) If the signal strength is always displayed as 0.00 there is no signal detected. Thus, it is necessary to check that the parameters (including all the pipe parameters) have been entered accurately. Check to be sure the transducer mounting method has been selected properly, the pipe is not worn-out, and the liner is not too thick. Make sure there is indeed fluid in the pipe or the transducer is not too close to a valve or elbow. Ascertain there is not too much air or solids in the fluid, etc. With the exception of these reasons, if there is still no signal detected, the measurement site has to be changed.
 - (5) Keep the flowmeter away from the electromagnetic interference area to ensure its proper operation..
 - (6) After completing the installation, power on the instrument and check the parameters and the result accordingly.

4. Operating Instructions

4.1 System Normal Identification

Press the "DIAG" keys. If " System Normal " displays on the screen, it indicates system normal.

Press the "DIAG" keys. If " NO Signal Detected " displays on the screen, it indicates problem that need to be addressed.

4.2 Low Flow Cutoff Value

The data in M4.02 is Low Flow Cutoff Value. If the flow rate falls below the low flow cutoff value, the flow indication is deemed to be ZERO. This can prevent the flow meter accumulate the flow when the actual flow is "0" after a pump was shut down. Generally, 0.03m/s is recommended to enter as the low flow cutoff point.

The low flow cutoff value has no relation to the measurement results once the velocity is higher than the low flow cutoff value.

4.3 Zero Settings

When zero flow occurs an instrument may have a zero point which shows a measured value is not equal to "0". This value indicates "Zero Offset". For any measuring instrument, the smaller the "Zero Offset" is, the better the accuracy will be. If the zero set point is not at true zero flow, a measurement error will occur. The smaller the measurement flow is, the larger the measurement error caused by the zero Offset will be. Only when zero point reduced to an acceptable degree can the measuring error caused by the zero point can be ignored.

For an ultrasonic flowmeter, the measurement error caused by the zero point cannot be ignored under low flow conditions. It is necessary to perform a static zero set calibration to improve the low flow measurement accuracy.

Set Zero in Menu 4.03, press , and then wait for the processing indication or displayed Complete. If setting Zero in flowing conditions, it may cause the flow to be displayed as "0". If so, it can be recovered via Menu 4.04.

4.4 Scale Factor

Scale factor refers to the ratio between "actual value" and "reading value". For example, when the measurement is 2.00, and it is indicated as 1.98 on the instrument, the scale factor reading is 2/1.98. This means that the best scale factor constant is 1. However, it is difficult to keep the scale factor as "1" on the instrument especially in batch productions. The difference is called "consistency".



During operation, there still exists possible difference in pipe parameters, etc. The "scale factor" may be necessary when used on different pipes. Thus, scale factor calibration is specially designed for calibrating the differences that result from application on different pipes. The scale factor entered must be one that results from actual flow calibration. The scale factor can be input in Window M4.06.

4.5 4 ~ 20mA Current Loop Output

With a current loop output exceeding an accuracy of 0.1%, the flowmeter is programmable and configurable with outputs such as 4 ~ 20mA selected in Menu 5.04. Please refer to Menu 5.5.4 in "Window Display Explanations" for more information.

In Window M5.05, enter a 4mA flow value. Enter the 20mA flow value in Window M5.06. For example, if the flow range in a specific pipe is 0 ~ 1000m³/h, enter 0 in Window M5.05 and 1000 in Window M5.06.

Calibrating and testing the current loop is performed in Window M5.07. Complete the steps as follows:

Press 5.07 , move  or  to display "4mA" "20mA", connect an ammeter to test the current loop output and calculate the difference and check whether the difference is within tolerance or not. Refer to Section 4.6 for Current Loop Verification.

Check the present current loop output in Window M5.08, the value will change along with the change of the flow.

4.6 4-20mA Analog Output Calibration







Attention

Each flowmeter has been strictly calibrated before leaving factory. It is unnecessary to carry out this step except when the current value (detected while calibrating the current loop) displayed in Window M5.07 is not identical with the actual output current value.

Calibration method for the Analog Input:

Appendix	
01. ON/OFF Time	Press ENT When Ready
02. Total Working Hours	00067 : 47 : 50
03. Last Power Off Time	15-06-21 10 : 11 : 43
04. Last Flow Rate	10.500m ³ /h
05. ON/OFF Times	67
06. Adjust AI	Press ENT When Ready
07. Adjust 4-20mA	>4ma

>Enter next menu, <-return fore menu, Enter:OK

Press  to enter password "115800", then press  again to confirm the password. Enter the Current Loop Calibration Interface, press  to enter the 4mA Calibration Status and use an ammeter to measure the output current of the current loop. Press  or  to adjust the displayed numbers until it reads 4.00mA. When it reads 4mA, the 4mA calibration is finished.

Press  to calibrate the current loop 20mA output with using the same method for 4mA calibration. The calibration results will be automatically saved in EEPROM and won't get lost even if the power is switched off.

4.7 TF Card Operation

4.7.1 Specifications

Capacity: 4 GB standard

Note: TF card is a kind of fashion consumer products, quickly upgrade. The specific configuration is subject to the product you received.

Data collection interval: the user can set any interval settings from 1 to 3600 seconds according to the requirement, the factory default is 2s.

Data content: date and time, flow rate, flow velocity, total flow, positive totalizer, negative totalizer.

Data storage format: 1=07-04-10,14:16:33

2=+3.845778E+01m³/h

3=+1.451074E+00m/s

4=-0000010E+0m³

5=+0000002E+0m³

6=-0000012E+0m³

File system format: FAT32.

File type: plain text file (.TXT).

File name format: yy-mm-dd (yy - year, mm - month, dd - date).

When the capacity of the SD card is full, the new data will override the earliest files automatically.

4.7.2 Reading the TF Data Offline

Remove the TF card from the flowmeter and insert into the TF card reader. Copy the data to the PC. Use "Converter.exe" software to convert the format when needed.

1. File converter (Click the "Offline" button and enter the Document Conversion Interface).

Press "Converter" button, convert the T card data format from ".TXT" to ".XLS", the interface is as follows:

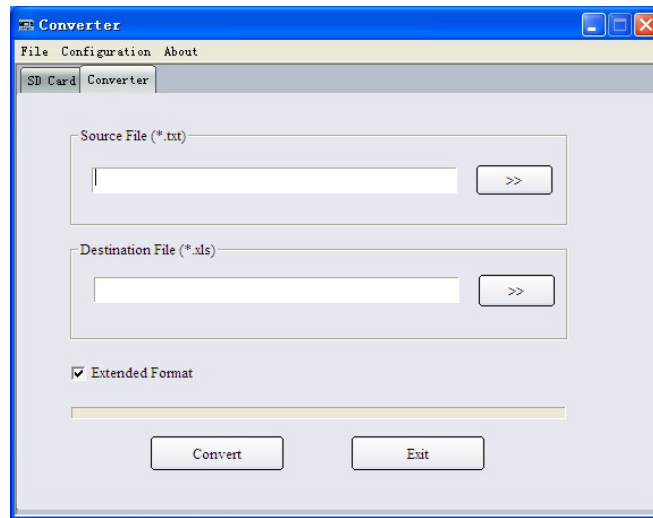

Select the file to be converted in "Source File (*.txt)", enter the directory path and the file name in "Destination File (*.xls)", then press "Convert". If "OK!" is displayed, the conversion is completed.

4.7.3 TF Card Storage Operation Guide

1. Press  key enter the TF Card Storage Settings Interface.

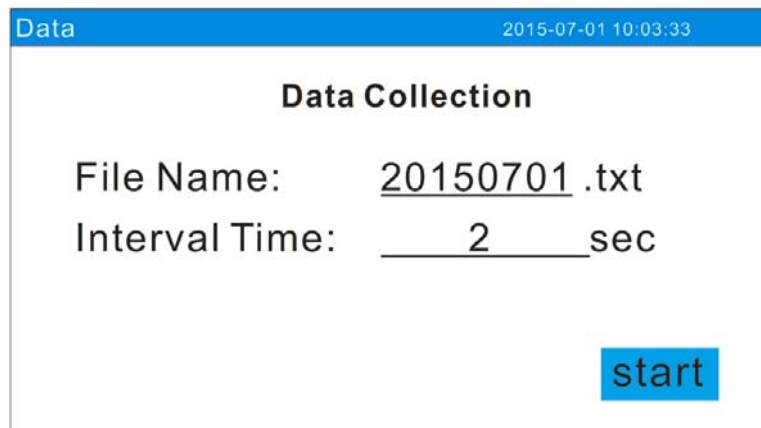

2. Completed the modification or use the default value, select "start", press  to start storage, normal storage as shown in the above diagram.(abnormal storage will show you the hints as the following diagram)

Data 2015-07-01 10:10:51

Data Collection

File Name: 20150701 .txt

Interval Time: 2 sec

No TF Card **start**

3. If you want to suspend the data storage, select "stop", "start", press  to stop or continue the data storage.

Note: the default boot TF card data, the date will be used to name the file, and the file name will automatically update when the date updates.

4.8 ESN

We provide the Flowmeter and Analyzer with a unique electronic serial number to identify each Flowmeter for the convenience of the manufacturer and customers. The ESN is able to be viewed in Window M5.10.

Attention: Please refer to "5 Windows Display Explanations" for more information.

5. Windows Display Explanation

5.1 Flow/Total Display

GENTOS		2015-07-01 10:06:13
Flow/Today display		
01.Flow /Net		2231x1 m3
02.Flow /Vel		5. 816m/s
03.Flow /POS		2231x1 m3
04.Flow /NEG		0x1 m3
05.Flow Rate		415. 622m3/h
06.Net Total Today		1360. 912m3

UP&DOWN : Choose,<--:Return previous menu,->:Enter next menu,Enter:OK

5.1.1 Display Flow/Net

5.1.2 Display Flow/Vel

5.1.3 Display Flow/POS

5.1.4 Display Flow/NEG

5.1.5 Display Flow Rate

5.1.6 Display Net Total Today

5.2 Initial Settings

		2015-07-01 10:04:43
Initial setup		
01.Pipe Outer Perimeter		628.32mm
02.Pipe Outer Diameter		200.00mm
03.Pipe Wall Thickness		6.00mm
04.Pipe Inner Diameter		188.00mm
05.Pipe Material		0. Carbon Steel
06.Pipe Sound Velocity		2424.00m/s
07.Liner Material		0. None,Liner
08.Liner Sound Velocity		0.0m/s
09.Liner Thickness		0.0mm
10.Fluid Type		0.Water

UP&DOWN : Choose,<--:Return previous menu,->:Enter next menu,Enter:OK

5.2.1 Input the Pipe Outer Perimeter

Enter the diameter of the pipe in window M2.01.

5.2.2 Input the Pipe Outer Diameter

Input pipe diameter directly, or input the perimeter in M2.01. The range of pipe outer diameter shall be from 10mm to 6000mm.

Note: Enter either pipe outer diameter or pipe outer perimeter.

5.2.3 Input the Pipe Wall Thickness

The pipe Wall thickness must be entered.

5.2.4 Input the Pipe Inner Diameter

Skip this step if the pipe outer diameter(or outer perimeter) and pipe wall thickness has been entered.

5.2.5 Pipe Material

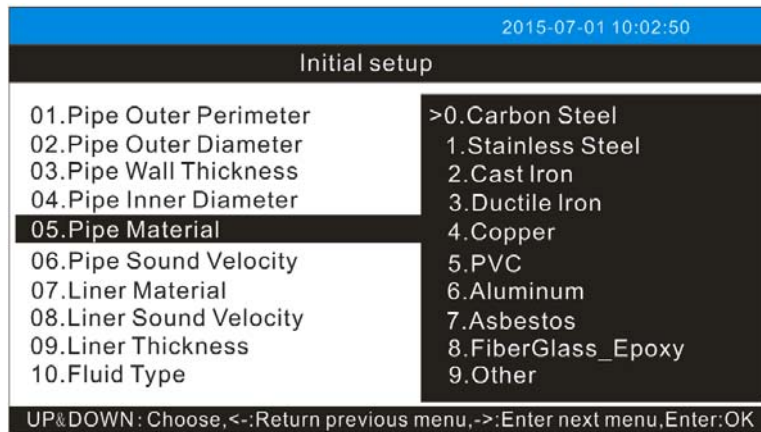

Enter pipe material. The following options are available (press to choose, press save and exit select mode):

- 0. Carbon Steel
- 1. Stainless Steel
- 2. Cast Iron
- 3. Ductile Iron
- 4. Copper
- 5. PVC
- 6. Aluminum
- 7. Asbestos
- 8. FiberGlass-Epoxy
- 9. Other

Item 9 "Other" is for entering other materials, which are not included in previous 8 items. Once Item 9 is selected, the relevant pipe sound velocity must be entered in Window M2.06.

5.2.6 Input the Pipe Sound Velocity

This function is only used when "Other" is selected in Window M2.05.

This window is not available when using M2.05 to choose the 0~8 Pipe Materials. The system will automatically enter the value according to the set parameters. Only when Item 9 is entered, must the pipe sound velocity be entered.

5.2.7 Liner Material

The following options are available:



- 0. None, Liner
- 1. Tar Epoxy

2. Rubber
3. Mortar
4. Polypropylene
5. Polystyrol
6. Polystyrene
7. Polyester
8. Polyethylene
9. Ebonite
10. Teflon
11. Other

Item 11 "Other" is available to enter other materials that are not included in previous ten items. Once the "Other" is selected, the relevant Liner Sound Velocity must be entered in Window M2.08.

5.2.8 Input the Liner Sound Velocity

This function is only used when Item "Other" is selected in M2.07, Otherwise only the selected Liner Sound Velocity can be viewed in M2.07.

5.2.9 Input the Liner Thickness

The liner thickness can only be set when a liner is selected in M2.07.

5.2.10 Fluid Type

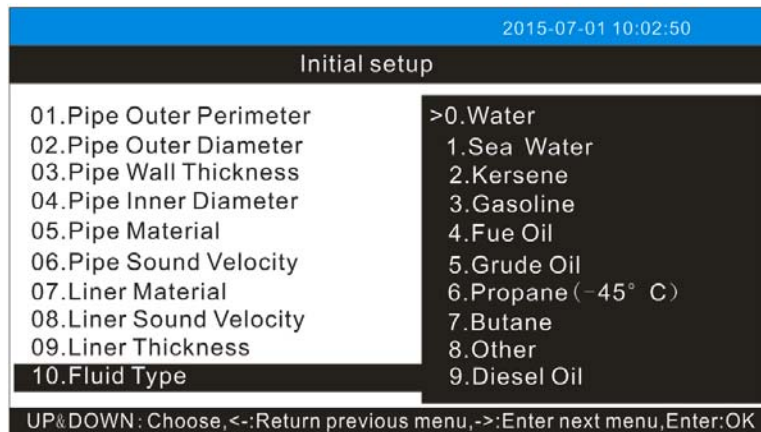

The following options are available:

0. Water
1. Sea Water
2. Kerosene
3. Gasoline
4. Fuel Oil
5. Crude Oil
6. Propane
7. Butane
8. Other
9. Diesel Oil
10. Castor Oil

11. Peanut Oil
12. Gasoline #90
13. Gasoline #93
14. Alcohol
15. Water @125°C

"Other" refers to any fluid. The relevant sound velocity must be entered in Window M2.11.

5.2.11 Input the Fluid Sound Velocity

Enter the fluid sound velocity. It can only be used when Item "Other" is selected in Window M2.10, i.e. it is unnecessary to enter this for all the fluids listed in Window M2.10. The default sound velocity list in M2.10 is unchangeable.

5.2.12 Input the Fluid Viscosity

Enter fluid's kinematics viscosity. It only can be used when Item "Other" is selected in Window M2.10, i.e. it is unnecessary to enter this for all the fluids that listed in Window M2.10. The default fluid viscosity set in the system is unchangeable.

5.2.13 Transducer Type

The following transducer types are available:

0. Standard
1. Plug in Type-B45
2. Plug in W110
3. Plug in WH101

5.2.14 Transducer Mounting

Three mounting methods are available:

0. V
1. Z
2. N (for small pipe)

5.2.15 Transducer Spacing

The operator must mount the transducer according to the transducer spacing displayed (Ensure the transducer spacing must be measured precisely during installation.) The system will display the data automatically after the pipe parameter has been entered.

5.2.16 Parameter Setups

Load and save the parameters. 16 different sets of setup conditions/groups are available to load and save by three methods:

0. Entry to Save
1. Entry to Load
2. To Browse

Select "Entry to Save", press enter An ID code and the original parameters are displayed in the window. Press UP or DOWN ARROW to move the ID code, then press the enter key again to save the current parameter in the current ID room.

When selecting "Entry to Load", press ENT, the system will read and calculate the parameters, and then automatically turn to the setting main interface.

5.2.17 Display Cross-sectional Area

5.3 Fluid Unit Settings

GENTOS		2015-07-01 10:08:52	
Fluid unit settings			
01.Measurement Units		0.Metric	
02.Flow Rate Units		m3/h	
03.Totalizer Units		0.m3	
04.Totalizer Multiplier		3.x1	
05.POS Totalizer		YES	
06.NEG Totalizer		YES	
07.NET Totalizer		YES	
08.Totalizer Reset		None	
09.Manual Totalizer		>OFF	2sec 0.000m3

UP&DOWN: Choose,<--:Return previous menu,->:Enter next menu,Enter:OK

5.3.1. Measurement Units

Select the measurement unit as follows:

- 0. Metric
- 1. English

The factory default metric

5.3.2. Flow Rate Units

GENTOS		2015-07-01 10:07:43	
Fluid unit settings			
01.Measurement Units		0.Metric	
02.Flow Rate Units		>0.m3	
03.Totalizer Units		1.l	
04.Totalizer Multiplier		2.gal	
05.POS Totalizer		3.ig	
06.NEG Totalizer		4.mg	
07.NET Totalizer		5.cf	
08.Totalizer Reset		6.bal	
09.Manual Totalizer		7.ib	
		8.0b	

UP&DOWN: Choose,<--:Return previous menu,->:Enter next menu,Enter:OK

The following flow rate units are available:

- 0. Cubic Meters (m3)
- 1. Liters (l)
- 2. USA Gallons (GAL)
- 3. Imperial Gallons
- 4. Million Gallons
- 5. Cubic Feet (cf)
- 6. USA Barrels
- 7. Imperial Barrels
- 8. Oil Barrels(ob)

The following time units are available:

- / Day / Hour
- / Min / Sec

Factory default is Cubic Meters/hour.

5.3.3. Totalizer Units

Select totalizer units. The available unit options are as same as those found in Window M5.3.2. The user can select units as their requirement. Factory default is Cubic Meters.

5.3.4. Totalizer Multiplier

The totalizer multiplier acts as the function to increase the Totalizer indicating range. Meanwhile, the Totalizer multiplier can be applied to the Positive Totalizer, Negative Totalizer and Net Totalizer. The following options are available:

0. x 0.001 (1E-3)
1. x 0.01
2. x 0.1
3. x 1
4. x 10
5. x 100
6. x 1000
7. x 10000(1E+4)

Factory default factor is x1

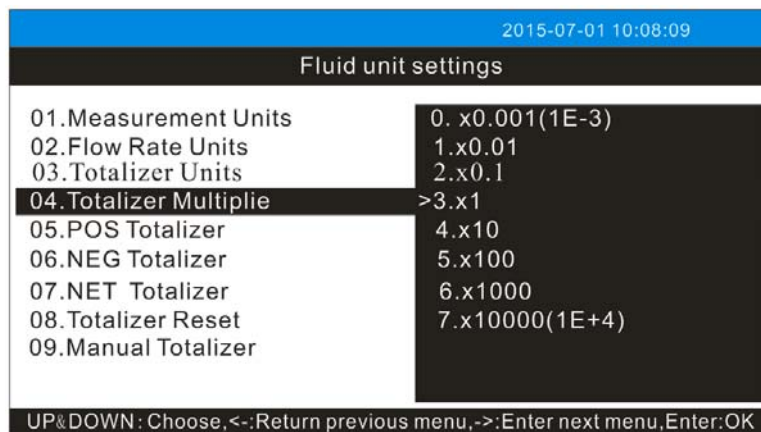

5.3.5 POS Totalizer

On/Off POS Totalizer. "ON" indicates the Totalizer is on while "OFF" indicates the Totalizer is off. When it is off, the POS Totalizer displays in the window will not change. Factory default is "ON".





5.3.6. NEG Totalizer

On/Off NEG Totalizer. "ON" indicates the Totalizer is on while "OFF" indicates the Totalizer is off. When it is off, the NEG Totalizer displays in the window will not change. Factory default is "ON".

5.3.7 NET Totalizer

On/Off NET Totalizer. "ON" indicates the Totalizer is on while "OFF" indicates the Totalizer is off. When it is off, the NET Totalizer displays in the window will not change. Factory default is "ON".

5.3.8 Totalizer Reset

Totalizer reset; all parameters are reset.; press  or  to select action items. Press  to perform the corresponding operation, if don't need a clear operation, click  to return to the next higher level ,the following options are available:

None

ALL Totalizer

- NET Totalizer
- POS Totalizer
- NEG Totalizer
- Reset

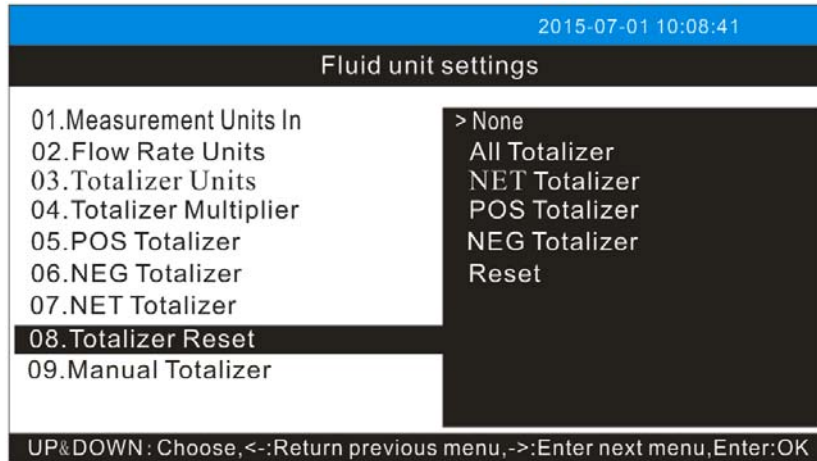



Factory Default If the user wants to delete all the current set parameters return setting back to the factory default, reset in this window and then the flow meter will return back to the factory default automatically.



Attention

This operation will delete all the current user’s data and back to the factory default. Please consider carefully before performing this operation.

5.3.9. Manual Totalizer

The manual totalizer is a separate Totalizer. Press  to start, and press  to stop it. It is used for flow measurement and calculation.

5.4 Select Settings

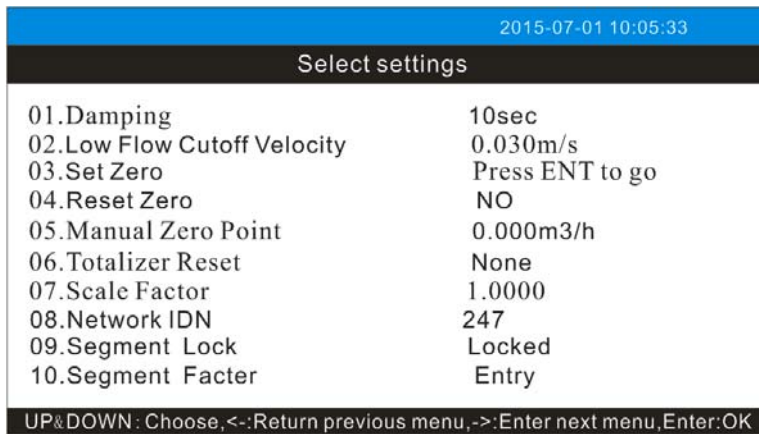

5.4.1 Input the Damping

The damping factor ranges from 0 ~ 999 seconds. 0 indicates no damping; 999 indicates the maximum damping. The damping function will stabilize the flow display .Its principle is the same as that in a single-section RC filter. The damping factor value corresponds to the circuit time constant. Usually a damping factor of 3 to 10 is recommended in applications.

5.4.2 Input the Low Flow Cutoff Value

If the flow rate falls below the low flow cutoff value, the flow indication is driven to zero. This function can

prevent the flowmeter reading flow after a pump is shut down but there is still liquid movement in the pipe, which will result in a totalized error. Generally, 0.03m/s is recommended to enter as the low flow cutoff point.

5.4.3 Set Zero

When zero flow occurs an instrument may have a zero point which shows the measured value is not equal to "0". This value indicates "Zero Offset". For any measuring instrument, the smaller the "Zero Offset" is, the better the accuracy will be.

If the zero point is not at true zero flow, a measurement error may occur. The smaller the measurement flow is, the larger the measurement error caused by the zero offset will be. Only when zero point is reduced to an acceptable degree can the measuring error caused by the zero offset be ignored.

For an ultrasonic flowmeter, the measurement difference caused by the zero point cannot be ignored under low flow conditions. It is necessary to perform a static zero set calibration to improve the low flow measurement accuracy.

Press  to set Zero and then wait for the processing indication or displayed complete. When the setting is completed, it will show as follows:

GENTOS		2015-07-01 10:07:43
Select settings		
01.Damping		10sec
02.Low Flow Cutoff Velocity		0.030m/s
03.Set Zero		>Press Enter to go
04.Reset Zero		NO
05.Manual Zero Point		0.000m ³ /h
06.Scale Factor		1.0000
07.Network IDN		88
08.System Lock		Unlocked
09.Segment Correction		NO
10.Segment Factor		Entry
UP&DOWN: Choose,<-:Return previous menu,->:Enter next menu,Enter:OK		

1. Zero Set Succeed, return back to the flow interface.
2. Zero Set Failed
3. Zero > 0.5m/s Failed

Press  to exit.



Attention

If in the case of traffic, perform the function, will cause the flow is shown as "0", can use M5.4.4 recovery.

5.4.4 Reset Zero

Select "YES";press  to clean all the operations, remove all Zero set by the user. Exit and the status still shows "NO".

5.4.5 Manual Zero Point

This method is not commonly used. It is only suitable for experienced operators to set zero under conditions when it is not preferable to use other methods. Enter the value manually to add to the measured value to obtain the actual value. For example:

Actual measured value = 250 m³/H

Value Deviation = -10 m³/H

Flowmeter Display = 240 m³/H

Normally, set the value as "0".

5.4.6 Scale Factor

The scale factor is used to modify the measurement results. The user can enter a numerical value according to the actual calibration results.

5.4.7 Network IDN

Input system identifying code, these numbers can be selected from 1 ~ 247 except that 13 (0DH ENTER), 10 (0AH Line feed), 42 (2AH*) and 38 (26H&) are reserved. System IDN is used to identify the flowmeter to a network.

5.4.8 System Lock

Lock the instrument. Once the system is locked, any modification to the system is prohibited, but the parameter is readable. Entering your designated password correctly can be the only way to "Unlock" the instrument. The password is composed of 6 numbers. (Please contact the representative or manufacturer as soon as possible when the password is lost.) Press "Unlock" to set the "new password", press  to permanently save the password.

Warm reminder: Please keep the new password in mind, and the factory code is 115800.

5.4.9 Segment Correction

ON: Turn on the Sectional Correction Function;

OFF: Turn off the Sectional Correction Function (optional)

Only when it is "ON", the settings of the Sectional Correction Value in M5.4.10 will be workable.

5.4.10 Segment Factor

2015-07-01 10:45:46		
Select setting		
01.Damping	> 0	0.0500m/s 0.0000
02.Low Cutoff Val.	1	0.1000m/s 0.0000
03.Set Zero	2	0.2000m/s 0.0000
04.Reset Zero	3	0.3400m/s 0.0000
05.Manual Zero Point	4	0.5000m/s 0.0000
06.Scale Factor	5	0.7000m/s 0.0000
07.Network IDN	6	1.0000m/s 0.0000
08.System Lock	7	1.4000m/s 0.0000
09.Segment Correction	8	2.0000m/s 0.0000
10.Segment factor	9	2.8000m/s 0.0000

UP&DOWN: Choose, <-:Return previous menu, ->:Enter next menu, Enter:OK

16 groups correction coefficient can be set for the sectional correction measurement results. The user can input the actual scale factor according to the calibration results. After the completion of input, move the cursor to 16 And press  to save the revised value.

5.5 Input and Output Settings

GENTOS		2015-07-01 10:05:50
Input and output settings		
01.AI1 Value		-12.51
02.AI2 Value		-12.49
03.AI3 Value		-12.50
04.CL Mode Select		0. 4-20mA vs Flow
05.CL 4mA Output Value		0.0000m3/h
06.CL 20mA Output Value		400.0000m3/h
07.CL Check		Press ENT When Ready
08.CL Current Output		4.000mA
09.YY-MM-DDHH:MM:SS		15-07-01 10:05:50
10.Ultrasonic Flowmeter S/N		S/N=50003270

UP&DOWN: Choose, <: Return previous menu, >: Enter next menu, Enter: OK

5.5.1 Input the AI1 Value

Display the analog value of the Analog Input AI1.

5.5.2 Input the AI2 Value

Display the analog value of the Analog Input AI2 .

5.5.3 Input the AI3 Value

Display the analog value of the Analog Input AI3 .

5.5.4 CL Mode Option

0.4-20mA vs Flow

1.4-20mA vs Vel

5.5.5 CL 4mA Output Value

Set the CL output value according to the flow value at 4mA. The flow unit is the same as specified in Window M5.3.2.





When select "4-20mA vs Vel." in M5.5.4, the unit should be set as m/s.

5.5.6 CL 20mA Output Value

Set the CL output value according to the flow value at 20mA. The flow unit is the same as specified in Window M5.3.2.

When select "4-20mA vs Vel." in M5.5.4, the unit should be set as m / s.

5.5.7 CL Calibration

Check if the current loop has been calibrated before leaving the factory. Press  to operate this function, press  to enter the calibration mode, move  or  to display "4mA" "20mA", connect an ammeter to test the current loop output and check whether there is any value displayed in the CL output I+ and I-. Re-calibrate the CL if the difference is over the permitted tolerance.

Press  to exit.

5.5.8 CL Current Output

Display CL current output. The display of 10.0000mA indicates that CL current output value is 10.0000mA. If the difference between displaying value and CL output value is too large, the current loop needs to be re-calibrated accordingly.

5.5.9 YY-MM-DD HH:MM:SS

Date and time modifications are made in this window.

The time setting format is 24 hours. Press  and wait until ">" appears, then make the modification

accordingly.

5.5.10 S/N of the instrument

Display electronic serial number (ESN) of the instrument. Each instrument has its unique ESN. The manufacturer sets files for the instrument and the user can manage their instrument with the ESN.

Input and output settings	
11.Rs232 Setup	9600
12.AI1 Value Range	0-100
13.AI2 Value Range	0-100
14.AI3 Value Range	0-100
15.FO Frequency Range	0-5000
16.Low FO Flow Rate	0.0000m ³ /h
17.High FO Flow Rate	40.0000m ³ /h
18.LCD Backlit Option	0.Always ON
19.Working Timer	00067:28:52
20.Alarm #1 Low Value	0.000m ³ /h

UP&DOWN: Choose, <:Return previous menu, >:Enter next menu, Enter:OK

5.5.11 Serial Port Settings

This window is used for setting the serial port. Serial port is used to communicate with other instruments. The serial port parameters setting of the instrument that applies the serial port connection must be consistent. The first selected data indicates baud rate, 9600, 19200, 38400, 56000, 57600, 115200 are available.

The second option indicates parity bit, None (No verification).

Data length fixed to 8;

Stop bit length fixed to 1.

The factory default serial port parameter is "9600, 8, None, 1".

5.5.12 AI1 Value Range

This window is used to input analog input 4 mA and 20 mA on behalf of the temperature or pressure value.

5.5.13 AI2 Value Range

This window is used to input analog input 4 mA and 20 mA on behalf of the temperature or pressure value.

5.5.14 AI3 Value Range

This window is used to input analog input 4 mA and 20 mA on behalf of the temperature or pressure value.

5.5.15 Frequency Output Range

Set the upper limit frequency value of the frequency output signal. The high FO must be higher than the low FO frequency. Ranges from 1-9999Hz. Factory default is 1 ~ 1001 Hz.

Note: The frequency output is transmitted through OCT Serial Port; therefore the OCT must be set to the frequency output mode.(select "FO" in M5.25)

5.5.16 Low FO Flow Rate

Set the low FO flow rate, i.e. the corresponding flow value when output signal frequency is at the lowest

FO frequency. For example, when the low FO frequency is 1000Hz, low FO flow rate is 100 m³/h. When the frequency output is 1000Hz, then the low flow at this moment measured by the flowmeter is 100 m³/h.

5.5.17 High FO Flow Rate

Enter the high FO flow rate, i.e. the corresponding flow value when frequency output signal is at the highest FO frequency. For example, when the high FO frequency is 3000Hz, high FO flow rate is 1000m³/h. When the frequency output is 3000Hz, then the low flow at this moment measured by the flowmeter is 1000m³/h.

5.5.18 LCD Backlit Control

- 0. Always ON
- 1. Always OFF
- 2. Lighting For 10S
- 3. Lighting For 30S
- 4. Lighting For 1Min
- 5. Lighting For 2Min
- 6. Lighting For 5Min

Select "Lighting For nn Sec", then enter the desired back lighting time for "n" seconds; it indicates that after pressing the button, the back lighting will keep on for "n" seconds then turn off automatically. This function saves energy. Keep the backlight on can save about 30mA electric current.

5.5.19 Working Timer

Display the totalized working hours of the flowmeter since the last reset. It is displayed by HH:MM: SS. If it needs a reset, press , and select "YES".

5.5.20 Alarm #1 Low Value

Enter the low alarm value. Both relevant alarms are turned on in Windows M5.26; any of the measured flow, which is lower than the low value, will activate the alarm in the OCT hardware or relay output signal.

Input and output settings	
21.Alarm #1 High Value	14400m3/h
22.Alarm #2 Low Value	0.000m3/h
23.Alarm #2 High Value	14400m3/h
24.Beeper Setup	OFF
25.OCT Output Setup	FO
26.Relay Output Setup	13.Not Using
27.Flow Batch Controller	1000
28.Date Totalizer	0.Day

UP&DOWN: Choose, <-: Return previous menu, ->: Enter next menu, Enter: OK

5.5.21 Alarm #1 High Value

Enter the high alarm value. Both relevant alarms are turned on in Windows M5.26; any of the measured flow, which is higher than the high value, will activate the alarm in the OCT hardware or relay output signal.

5.5.22 Alarm #2 Low Value

Enter the alarm low value. Both relevant alarms are turned on in Windows M5.26; any measured flow, which is lower than the low value, will activate the alarm in the OCT hardware or relay output signal.

5.5.23 Alarm #2 High Value

Enter the alarm low value. Both relevant alarms are turned on in Windows M5.26; any measured flow, which is lower than the low value, will activate the alarm in the OCT hardware or relay output signal.

5.5.24 Beeper Setup

Set the beeper's on-off status.

5.5.25 OCT Output Setup

Set the trigger event source for the OCT output hardware unit output, the triggering event of this instrument is FO

5.5.26 Relay Output Setup

This menu is used to set the trigger event source for the RELAY output hardware unit. The RELAY is single-pole

and constant-on for external instrument controls. The following options are available:

- 0. No Signal
- 1. Poor Signal
- 2. Not Ready (No*R)
- 3. Reverse Flow
- 4. AO Over 100%
- 5. FO Over 120%
- 6. Alarm #1
- 7. Alarm #2
- 8. Batch Control
- 9. POS Int Pulse
- 10. NEG Int Pulse
- 11. NET Int Pulse
- 12. Serial Port Control
- 13. Not Using

5.5.27 Flow Batch Controller

Flow Batch Controller also known as quantitative controllers, flow meter built-in batch controller, enter the quantitative control value in this menu and press  to enter the batch control interface.





Press  to start the accumulation, when the net totalizer reaches the set value, it will end and the beeper will alarm.

5.5.28 Date Totalizer

Input and output settings		
21. Alarm #1 High Value	> 1 07-01	0.000
22. Alarm #2 Low Value	2 06-30	1514.000
23. Alarm #2 High Value	3 06-29	0.000
24. Beeper Setup	4 06-28	0.000
25. OCT Output Setup	5 06-27	0.000
26. Relay Output Setup	6 06-26	0.000
27. Flow Batch Controller	7 06-25	0.000
28. Date Totalizer	8 06-24	0.000
	9 06-23	0.000
	10 06-22	0.000

UP&DOWN: Choose, <-:Return previous menu, ->:Enter next menu, Enter:OK

In this window, it is possible to review the historical flow data totalizer for any day of the last 64 days, any month of last 64 months and any year of last 5 years.

Move  or  to review totalizer by days, months and years.



The following options are available:

“0” By days

“1” By Months

“2” By Years

Press  to view the corresponding item, and the corresponding flow of 64 days.

For example: when the cursor ">" displays in the date, press  to view the NET Totalizer of 10 working days in the 64 working days, moving the cursor up and down to view the totalizer of other date. Press  to exit .

5.6 Diagnosis

GENTOS		2015-07-01 10:06:29	
Diagnosis			
01.Strength and Quality		UP: 67.6	DN: 67.6 Q=99
02.TOM/TOS*100		100.6%	
03.Fluid Sound Velocity		1491.6m/s	
04.Total Time and Delta		247.01us	-2.29ns
05.Reynolds Number and Factor		156	1.168

UP&DOWN: Choose,->:Return previous menu,->:Enter next menu,Enter:OK

5.6.1 Signal Strength and Signal Quality

Display the measured signal strength and signal quality Q value upstream and downstream.

Signal strength is indicated from 00.0 ~ 99.9. A reading of 00.0 indicates no signal detected, while 99.9 indicates maximum signal strength. Normally the signal strength should be ≥ 60.0 .

Signal quality Q is indicated by 00 ~ 99. Therefore, 00 indicates the poorest signal while 99 indicates the best signal. Normally, signal quality Q value should be better than 50.

5.6.2 TOM/TOS*100

Display the ratio between the actual measured transmit time and the calculated transmit time according to customer's requirement. Normally the ratio should be $100 \pm 3\%$. If the difference is too large, the user should check that the parameters are entered correctly, especially the sound velocity of the fluid and the installation of the transducers.

This data is of no use before the system is ready.

5.6.3 Fluid Sound Velocity

Display the measured fluid sound velocity. Normally this value should be approximately equal to the entered value in Window M2.11. If the difference is too large, it probably results from an incorrect value entered in Window M2.11 or improper installation of the transducers.

5.6.4 Total Time and Delta

Display the measured ultrasonic average time (unit: uS) and delta time of the upstream and downstream (unit: nS) time. The velocity calculation in the flowmeter is based on the two readings. The delta time is the best indication that the instrument is running steadily. Normally the fluctuation in the ratio of the delta time should be lower than

20%. If it is not, it is necessary to check if the transducers are installed properly or if the parameters have been entered correctly.

5.6.5 Reynolds Number and Factor

Display the Reynolds number that is calculated by the flowmeter and the factor that is set currently by the flowmeter. Normally this scaling factor is the average of the line and surface velocity factor inside the pipe.

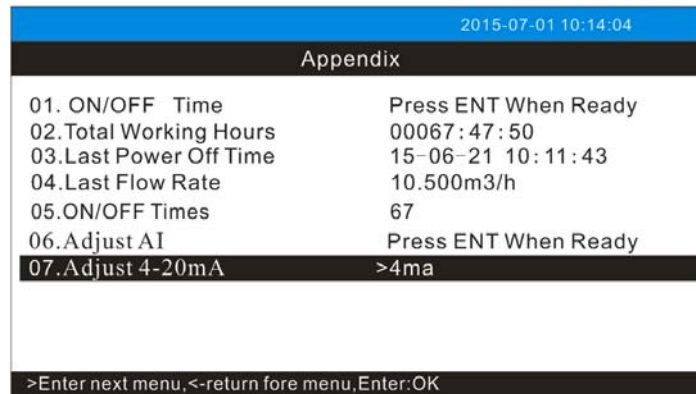

5.7 Appendix



5.7.1 ON/OFF Time



To view the power on/off time and flow rate for the last 64 update times, and obtain the offline time period and the corresponding flow rate.

Press   to view the last update before the last 64 times of on/off time and flow rate values. "ON" indicates that time is power on and the flow when power on; "OFF" indicates that time is power off and the flow when power off.

5.7.2 Total Working Hours



5.7.3 Last Power Off Time

5.7.4 Last Flow Rate

5.7.5 ON/OFF Times

Display total on / off times since the flowmeter left the factory.

5.7.6 Adjust AI

Connect the analog input to standard 20mA, input the password 115800 for calibration, press  or  to adjust the AI value to the upper limit of the AI range.

5.7.7 Adjust 4-20mA

Please refer to Chapter 4.6 "4-20mA Current Loop Output" for more details.

6. Error Diagnoses

The flow meter and analyzer adopts a high-reliability design, with lower failure rate. However, due to the unskillful operation by the user, incorrectly setting or bad working conditions, some problems might exist. Press

 when the window displays "System Normal", it indicates normal operation; if the window displays "No Signal Detected", it indicates abnormal operation, no signal.

6.1 Frequently Asked Questions and Answers

Question: New pipe, high quality material, and all installation requirements met: why still no signal detected ?

Answer: Check pipe parameter settings, installation method and wiring connections. Confirm if the coupling compound is applied adequately, the pipe is full of liquid, transducer spacing agrees with the screen readings and the transducers are installed in the right direction.

Question: Old pipe with heavy scale inside, no signal or poor signal detected: how can it be resolved?

Answer: Check if the pipe is full of fluid. Try the Z method for transducer installation (If the pipe is too close to a wall, or it is necessary to install the transducers on a vertical or inclined pipe with flow upwards instead of on a horizontal pipe).

Carefully select a good pipe section and fully clean it, apply a wide band of coupling compound on each transducer face (bottom) and install the transducer properly.

Slowly and slightly move each transducer with respect to each other around the installation point until the maximum signal is detected. Be careful that the new installation location is free of scale inside the pipe and that the pipe is concentric (not distorted) so that the sound waves do not bounce outside of the proposed area.

For pipe with thick scale inside or outside, try to clean the scale off, if it is accessible from the inside. (Note: Sometimes this method might not work and sound wave transmission is not possible because of the a layer of scale between the transducers and pipe inside wall).

7. Product Overview

7.1 Introduction

The Model D118i Ultrasonic Flowmeter is a state-of-the-art universal transit-time flowmeter designed using ARM COMA technology and low-voltage broadband pulse transmission. While principally designed for clean liquid applications, the instrument is tolerant of liquids with the small amounts of air bubbles or suspended solids found in most industrial environments

7.2 Features of D118i

Comparing With other traditional flowmeter or ultrasonic flowmeter, it has distinctive features such as high precision, high reliability, high capability and low cost, the Flowmeter features other advantages:

1. With ARM COMA chip, low power consumption, high reliability, anti-jamming and outstanding benefits.
2. User-friendly menu designed. Parameters of pipe range, pipe material, pipe wall thickness, output signals, etc can be conveniently entered via the windows. British and Metric measurement units are available.
3. With the TF Card, 512 files can be stored; the time interval can be within 1 second.
4. Parallel operation of positive, negative and net flow totalizer with scale factor and 7 digit display. Internally configured batch controller makes batch control convenient.

The flow meter ensures the higher resolution and wider measuring range by the 0.04nS high resolution, high linearity and high stability time measuring circuit and 32 bits digits processing program.

7.3 Theory of Operation

This Ultrasonic Flowmeter and Analyzer adopts the time-difference measurement principle. The ultrasonic waves emitted by the sensor in a fluid, the flowing in the propagation direction of acoustic wave propagation velocity downstream increases, decreases the upstream direction, have different propagation distance in the same transmission time, measure the flow rate according to the difference of the transmission time and the fluid flow

velocity.

When the ultrasonic signal is transmitted through the flowing liquid, there will be a difference between the upstream and downstream transit time (travel time or time of flight), which is proportional to flow velocity, according to the formula below.

$$V = \frac{MD}{\sin 2\theta} \times \frac{\Delta T}{T_{up} \cdot T_{down}}$$

Remarks:

V Medium Velocity

M Ultrasonic frequency of reflection

D Pipe Diameter

θ The angle between the ultrasonic signal and the flow

T_{up} Transit time in the forward direction

T_{down} Transit time in the reverse direction

$$\Delta T = T_{up} - T_{down}$$

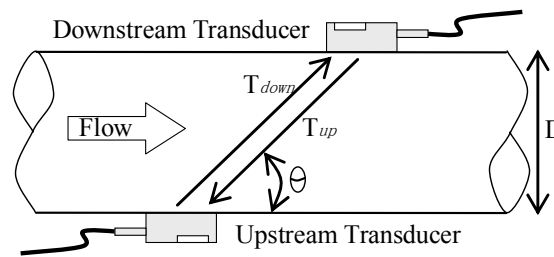

7.4 Applications

Water, sewage (with low particle content) and seawater; Acid alkali liquor, edible oil, diesel oil, crude oil, alcohol, beer, etc.

Water plant and sewage treatment plants;

Plant irrigation;

Metallurgy and mining applications (cooling water and acid recovery, for example)

Petroleum and chemicals;

Food and medicine;

Energy-saving monitoring, water-saving management and flow inspection, flow tracking and collection, computerized management and monitoring network system.

7.5 Specifications

Performance specifications	
Flow Range	0~±40ft/s(±0.01~12m/s)
Accuracy	±0.5% of measured value
Repeatability	0.1%
Pipe Size	1" ~200" (25mm~5000mm)
Function Specifications	
Output	Analog output: 4~20mA, maximum: 750Ω Pulse output: 0~9999Hz, OCT output (adjustable) Relay output: the highest 1Hz (1A@125VAC or 2A@30VDC)
Communication	RS-232/RS-485 Communication Interface,Support Modbus Protocol
TF Card	Max record: 4GB Storage time interval: 1 ~13000 s
Power Supply	90~250VAC@48~63Hz or 10~36VDC
Keypad	24 light tactile keys
Display	4.7 inch TFT color screen
Temperature	Transmitter:-10℃~60℃ Transducer:- 40℃~80℃ (standard)
Humidity	Up to 0 ~ 99% RH, non-condensing
Physical specifications	
Transmitter	Die-cast aluminum, IP65
Transducer	Encapsulated design., Protection grade IP68 The standard length of cable:9m
Weight	Transmitter:1kg

8. Appendix1- Flow Application Data

8.1 Sound Velocity and Viscosity for Fluids Commonly Used

Fluid	Velocity (m/s)	Viscosity
water 20°C	1482	1.0
water 0°C	1543	0.55
water 75°C	1554	0.39
water 100°C	1543	0.29
water 125°C	1511	0.25
water 150°C	1466	0.21
water 175°C	1401	0.18
water 200°C	1333	0.15
water 225°C	1249	0.14
water 250°C	1156	0.12
Acetone	1190	
Carbinol	1121	

Ethanol	1168	
Alcohol	1440	1.5
Glycol	1620	
Glycerin	1923	1180
Gasoline	1250	0.80
Benzene	1330	
Toluene	1170	0.69
Kerosene	1420	2.3
Petroleum	1290	
Retinal	1280	
Aviation kerosene	1298	
Peanut oil	1472	
Castor oil	1502	

8.2 Sound Velocity for Various Materials Commonly Used

Pipe Material	Sound Velocity (m/s)
Steel	3206
ABS	2286
Aluminum	3048
Brass	2270
Cast iron	2460
Bronze	2270
Fiber glass-epoxy	3430
Glass	3276
Polyethylene	1950
PVC	2540

Liner Material	Sound Velocity (m/s)
Teflon	1225
Titanium	3150
Cement	4190
Bitumen	2540
Porcelain enamel	2540
Glass	5970
Plastic	2280
Polyethylene	1600
PTFE	1450
Rubber	1600

8.3 Sound Velocity in Water (1 atm) at different temperatures

t(°C)	v(m/s)				
0	1402.3	33	1515.7	67	1554.0
1	1407.3	34	1517.7	68	1554.3
2	1412.2	35	1519.7	69	1554.5
3	1416.9	36	1521.7	70	1554.7
4	1421.6	37	1523.5	71	1554.9
5	1426.1	38	1525.3	72	1555.0
6	1430.5	39	1527.1	73	1555.0
7	1434.8	40	1528.8	74	1555.1
8	1439.1	41	1530.4	75	1555.1
9	1443.2	42	1532.0	76	1555.0
10	1447.2	43	1533.5	77	1554.9
11	1451.1	44	1534.9	78	1554.8
12	1454.9	45	1536.3	79	1554.6
13	1458.7	46	1537.7	80	1554.4
14	1462.3	47	1538.9	81	1554.2
15	1465.8	48	1540.2	82	1553.9
16	1469.3	49	1541.3	83	1553.6
17	1472.7	50	1542.5	84	1553.2
18	1476.0	51	1543.5	85	1552.8
19	1479.1	52	1544.6	86	1552.4
20	1482.3	53	1545.5	87	1552.0
21	1485.3	54	1546.4	88	1551.5
22	1488.2	55	1547.3	89	1551.0
23	1491.1	56	1548.1	90	1550.4
24	1493.9	57	1548.9	91	1549.8
25	1496.6	58	1549.6	92	1549.2
26	1499.2	59	1550.3	93	1548.5
27	1501.8	60	1550.9	94	1547.5
28	1504.3	61	1551.5	95	1547.1
29	1506.7	62	1552.0	96	1546.3
30	1509.0	63	1552.5	97	1545.6
31	1511.3	64	1553.0	98	1544.7
32	1513.5	65	1553.4	99	1543.9
		66	1553.7		

Please contact the manufacturer for the sound velocity of other fluids and materials.

9. Appendix2– Network and Communications Protocol

9.1 Overview

The flowmeter is equipped with sound communication protocol. It can also be connected to a RS-485 bus.

Two basic schemes can be chosen for networking, i.e. Either the analog current output method or the RS232 serial port communication method. The former method is suitable for replacing the aged equipment of the old version monitoring network, while the later method is suitable for the updated monitoring network system, with lower investment and more reliable operation.

When directly use the serial port communications method to implement a monitoring network system, the address identification code (in window M46) of the flowmeter shall be used as a network address code. Expanded command set with [W] is used as the communication protocol. The analog current loop and OCT output of flowmeter can be used to control the on/off of a control valve. The relay output can be used to power-on/off other equipment. The analog input of the system can be used to input signals such as pressure and temperature. The system provides a sound RTU function for the flow measurement.

RS-232 (cable length 0 ~ 15m) or RS-485 (cable length 0 ~ 1000m) can be directly used for data transmission links for a short distance. Current loop can be used in medium or long distance transmission.

When the flowmeter is used in a network environment, various operations can be performed by a host device, except for programming of the address identification code, which needs to be done via the flowmeter keyboard.

The command answer mode is used in data transmission, i.e. the host device issues commands and the flowmeter answers correspondingly.



Attention

RS232 and RS485 serial communications can not be used at the same time.

9.2 Serial Port Definitions

Flowmeter -RS232:	PIN 3 TXD send
TXD send	PIN 4 ground
RXD receive	PIN 5 ground
GND ground	PIN 6 empty
PC:	PIN 7 empty
PIN 1 empty	PIN 8 empty
PIN 2 RXD send	PIN 9 empty

9.3 RS232 Connection

See the below definitions of the flowmeter's serial port :

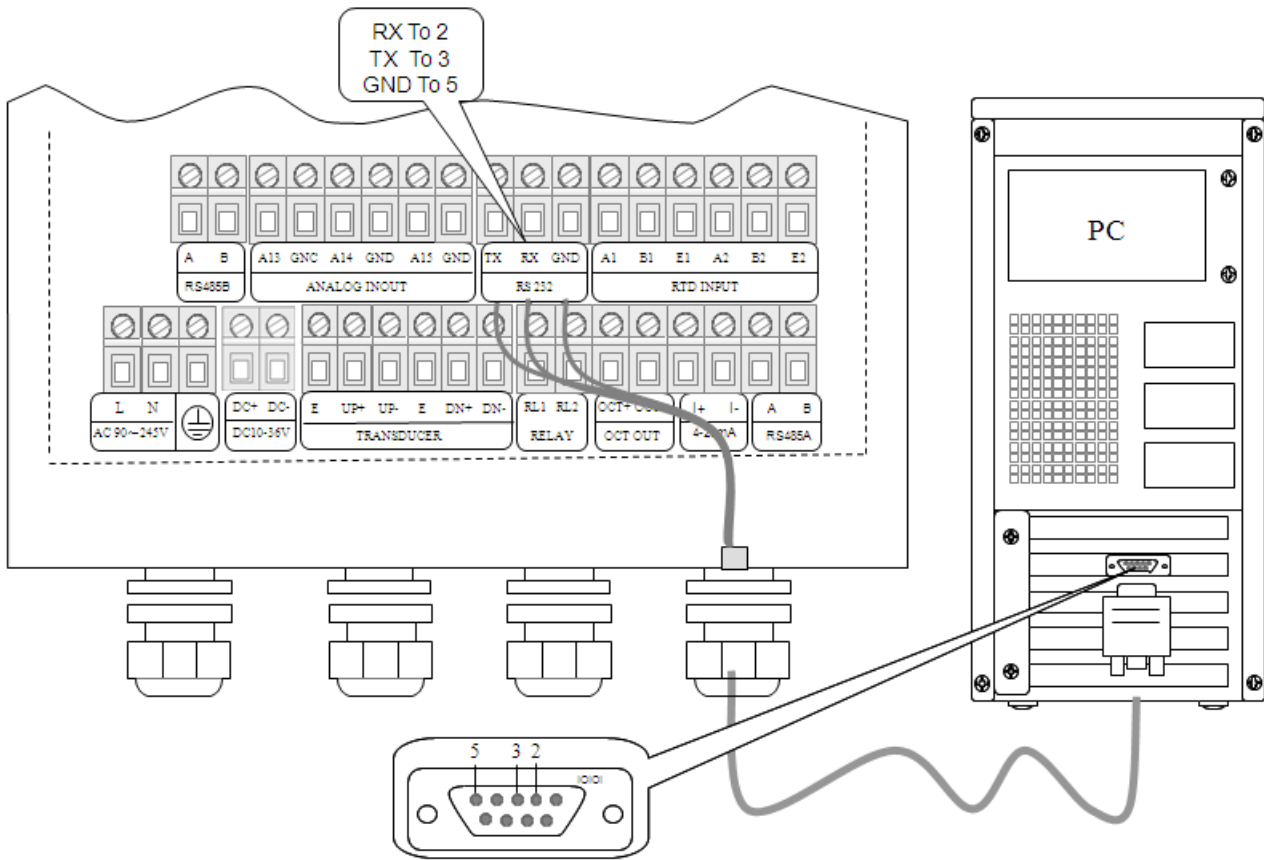

9.4 Communications Protocol And The Use

The flowmeter meter supports two communication protocols: FUJI Protocol, MODBUS Protocol.



Attention:

Incorrect protocol settings of the flowmeter might lead to abnormal communication.I

9.4.1FUJI Protocol

The communication protocol format used by the ultrasonic flowmeter is an expanded set of the Fuji FLV series flowmeter protocol. The host device requests the flowmeter to answer by sending a "command". The baud rate of asynchronous communication (Primary station: computer system; Secondary station: ultrasonic flowmeter) is generally 9600BPS. A single byte data format (10 bits): one start bit, one stop bit and 8 data bits. Check bit: none. A data character string is used to express basic commands and a carriage return (ENTER) is used to express the end of a command. The characteristic is that the string of data is flexible. The order applies to both RS232 and RS485. Frequently used commands are as follows:

Communications commands:

Command	Description	Data format
DQD(cr)(lf) Note:0	Return daily instantaneous flow	±d.ddddE±dd(cr) Note:1
DQH(cr)(lf)	Return hourly instantaneous flow	±d.ddddE±dd(cr)
DQM(cr) (lf)	Return instantaneous flow per minute	±d.ddddE±dd(cr)
DQS(cr) (lf)	Return instantaneous flow per second	±d.ddddE±dd(cr)
DV(cr) (lf)	Return instantaneous velocity	±d.ddddE±dd(cr)
DI+(cr) (lf)	Return positive accumulative flow	±ddddE±d(cr) Note:2
DI-(cr) (lf)	Return negative accumulative flow	±ddddE±d(cr)
DIN(cr) (lf)	Return totalized energy value	±ddddE±d(cr)
DID(cr) (lf)	Return identification code of instrument (address code)	dddd(cr)5 bits in length
DL(cr) (lf)	Return signal intensity	UP:dd.d, DN:dd.d, Q=dd(cr)
DC(cr) (lf)	Return current error code	Note:3
DT(cr) (lf)	Current date and time	yy-mm-dd, hh:mm:ss(cr)
M@(cr) (lf)	Analogous key value @ sent to flowmeter @	M@(cr) Note:4
ESN(cr) (lf)	Return electronic serial number	dddddt(cr)(lf) Note:5
W	Networking command prefix of numeric string address	Note:6
P	Prefix of return command with check	
&	Function sign of command "add"	

Note:

0. (cr)expresses carriage return. Its ASCII value is 0DH. (lf) expresses line feed. Its ASCII value is 0AH.

1."d" expresses 0-9 number. 0 value is expressed as +0.000000E+00.

2."d" expresses 0-9 numbers. There is no decimal point in integral part before "E".

3. The status of the machine is expressed by 1-6 letters. See the error code section for the meaning of the characters. For example, "R" and "IH".

4."@" expresses the key value. For example, 30H expresses "0" key; Command "M4" is equivalent to pressing the key "4".

5. Eight "ddddddd" expresses the electronic serial number of the machine. "t" expresses the type of machine.

6. If there are multiple flowmeters in a data network then the basic commands cannot be used alone. The prefix W must be added. Otherwise, multiple flowmeters will answer simultaneously, which will cause chaos in the system.

9.4.2 Function Prefix And Function Sign

(1)Prefix P

The character P can be added before every basic command. It means that the transferred data has CRC verification. The method of counting the verified sum is achieved by binary system addition.

For example: Command DI+(CR) (the relative binary system data is 44H, 49H, 2BH, 0DH) transferred data is + 1234567E+0m3. (CR) (the relative binary system data is 2BH, 31H, 32H, 33H, 34H, 35H, 36H, 37H, 45H, 2BH, 30H, 6DH, 33H, 20H, 0DH, 0AH). And command PDI + (CR) transferred data is +1234567E+0m3! F7 (CR), "!" means the character before it is the sum character, and the verified sum of the two bytes after it is (2BH+31H+32H+33H+34H+35H+ 36H+37H+45H+2BH+30H+6DH+33H+20H = (2) F7H).

Note: There can be no data before " ! ", and also may be a blank character.

(2)Prefix W

Usage of prefix W: W+ numeric string address code +basic command. Value range of the numeric string is 0 ~ 65535, except 13 (0DH carriage return), 10 (0AH line feed), 42 (2AH *) and 38 (26H &). If the instantaneous velocity of No. 12345 flowmeter is to be accessed, the command W12345DV(CR) can be issued. Corresponding binary code is 57H, 31H, 32H, 33H, 34H, 3 5H, 44H, 56H and 0DH.

(3)Function sign &

Function sign & can add up to 5 basic commands (Prefix P is allowed) together to form a compound command sent to the flowmeter together. The flowmeter will answer simultaneously. For example, if No. 4321 flowmeter is requested to simultaneously return: 1] instantaneous flow, 2] instantaneous flow velocity, 3] positive total flow, 4] energy total, 5] All analogous input current value, the following command is issued:

W4321PDQD & PDV&PDI + &PDIE&PBA1 (CR)

Simultaneously returned data are likely as follows:

+0.000000E+00m3/d!AC(CR)

+0.000000E+00m/s!88(CR)

+1234567E+0m3 !F7(CR)

+0.000000E+0GJ!DA(CR)

+7.838879E+00mA!59(CR)

9.4.3 MODBUS Communication Protocol

This MODBUS Protocol uses RTU transmission mode. The Verification Code uses CRC-16-IBM (polynomial is $X^{16}+X^{15}+X^2+1$, shield character is 0xA001) which is gained by the cyclic redundancy algorithm method.

MODBUS RTU mode uses hexadecimal to transmit data.

1. MODBUS Protocol Function Code and Format

The flow meter protocol supports the following two-function codes of the MODBUS:

Function Code	Performance data
0x03	Read register
0x06	Write single register

2. MODBUS Protocol function code 0x03 usage

The host sends out the read register information frame format:

Slave Address	Operation Function Code	First Address Register	Register Number	Verify Code
1 byte	1 byte	2 byte	2 byte	2 byte
0x01~0xF7	0x03	0x0000~0xFFFF	0x0000~0x7D	CRC(Verify)

The slave returns the data frame format:

Slave Address	Read Operation Function Code	Number of Data Bytes	Data Bytes	Verify Code
1 byte	1 byte	1 byte	N*x2 byte	2 byte
0x01~0xF7	0x03	2xN*	N*x2(Data)	CRC(Verify)

N*=Data register number

3. MODBUS Protocol function code 0x06 usage

The host sends a command to write a single register information frame format (function code 0x06):

Slave Address	Operation Function Code	Register Address	Register Data	Verify Code
1 byte	1 byte	2 byte	2 byte	2 byte
0x01~0xF7	0x06	0x0000~0xFFFF	0x0000~0xFFFF	CRC(Verify)

The slave returns the data frame format (function code 0x06):

Slave Address	Operation Function Code	Register Address	Register Data	Verify Code
1 byte	1 byte	2 byte	2 byte	2 byte
0x01~0xF7	0x06	0x0000~0xFFFF	0x0000~0xFFFF	CRC(Verify)

The range of flow meter addresses 1 to 247 (Hexadecimal: 0x01 ~ 0xF7), and can be checked in the Menu 46. For example, decimal number "11" displayed on Menu 46 means the address of the flow meter in the MODBUS protocol is 0x0B.

The CRC Verify Code adopts CRC-16-IBM (polynomial is $X^{16}+X^{15}+X^2+1$, shield character is 0xA001) which is gained by the cyclic redundancy algorithm method. Low byte of the verify code is at the beginning while the high byte is at the end.

For example, to read the address 1 (0x01) in the RTU mode, if the instantaneous flow rate uses hour as a unit (m³/h), namely reads 40005 and 40006 registers data, the read command is as follows:

0x01 0x03 0x00 0x04 0x00 0x02 0x85 0xCA

Flowmeter Address Function Code First Address Register Register Numbers CRC Verify Code

Flowmeter returned data is (assuming the current flow=1.234567m³/h)

0x01 0x03 0x04 0x06 0x51 0x3F 0x9E 0x3B 0x32

Flowmeter Address Function Code Data Bytes Data (1.2345678) CRC Verify Code

The four bytes 3F 9E 06 51 is in the IEEE754 format single precision floating point form of 1.2345678.

Pay attention to the data storage order of the above example. Using C language to explain the data, pointers can be used directly to input the required data in the corresponding variable address, the low byte will be put at the

beginning, such as the above example 1.2345678 m/s, 3F 9E 06 51 data stored in order as 51 06 9E 3F.

For example, it converts the address 1 (0x01) to 2 (0x02) under the RTU mode, so to write the data of flowmeter 44100 register as 0x02, the write command is as follows:

0x01	0x06	0x10 0x03	0x00 0x02	0xFC 0xCB
Flowmeter Address	Function Code	Register Address	Register Number	CRC Verify Code

Flowmeter returned data is:

0x01	0x06	0x10 0x03	0x00 0x02	0xFC 0xCB
Flowmeter Address	Function Code	Register Address	Register Number	CRC Verify Code

4.Error Check

The flowmeter only returns one error code 0x02 which means data first address in error.

For example, to read address 1 (0x01) of the flowmeter 40002 register data in the RTU mode, the flowmeter considers it to be invalid data, and sends the following command:

0x01	0x03	0x00 0x01	0x00 0x01	0xD5 0xCA
Flowmeter Address	Function Code	Register Address	Register Number	CRC Verify Code

Flowmeter returned error code is:

0x01	0x83	0x02	0xC0 0xF1
Flowmeter Address	Error Code	Error Extended Code	CRC Verify Code

9.4.4 MODBUS Register Address List

The flowmeter MODBUS Register has a read register and a write single register.

(1)Read Register Address List (use 0x03 function code to read)

PDU	Register	Read	Write	Type	No. registers*
\$0000	40001	Flow/s - low word	32 bits real	2	
\$0001	40002	Flow/s - high word			
\$0002	40003	Flow/m - low word	32 bits real	2	
\$0003	40004	Flow/m- high word			
\$0004	40005	Flow/h - low word	32 bits real	2	
\$0005	40006	Flow/h - high word			
\$0006	40007	Velocity – low word	32 bits real	2	
\$0007	40008	Velocity – high word			
\$0008	40009	Positive total – low word	32 bits int.	2	
\$0009	40010	Positive total – high word			
\$000A	40011	Positive total – exponent	16 bits int.	1	
\$000B	40012	Negative total – low word	32 bits int.	2	
\$000C	40013	Negative total – high word			
\$000D	40014	Negative total – exponent	16 bits int.	1	
\$000E	40015	Net total – low word	32 bits int.	2	
\$000F	40016	Net total – high word			
\$0010	40017	Net total – exponent	16 bits int.	1	
\$0016	40023	Up signal int – low word	32 bits real	2	0~99.9
\$0017	40024	Up signal int – high word			
\$0018	40025	Down signal int – low word	32 bits real	2	0~99.9
\$0019	40026	Down signal int – high word			
\$001A	40027	Quality	16 bits int.	1	0~99
\$001D	40030	Error code – char 1,2	String	3	Refer to "Error Analysis" for detailed codes meanings.
\$001E	40031	Error code – char 3,4			
\$001F	40032	Error code – char 5,6			
\$003B	40060	Velocity unit – char 1,2	String	2	Currently supports m/s only
\$003C	40061	Velocity unit – char 3,4			
\$003D	40062	Flow unit – char 1,2	String	2	
\$003E	40063	Flow unit – char 3,4			
\$003F	40064	Total unit – char 1,2	String	1	Note 1
\$0043	40068	D code – low word	32 bits int.	2	
\$0044	40069	ID code – high word			
\$0045	40070	Serial number – char 1,2	String	4	
\$0046	40071	Serial number – char 3,4			
\$0047	40072	Serial number – char 5,6			
\$0048	40073	Serial number – char 7,8			

(2)Single Write Register Address List (use 0x06 performance code to write)

PDU Address	Register	Description	Read/Write	Type	No. registers
\$1003	44100	Flowmeter address (1-247)	R/W	16 bits int.	1
\$1004	44101	Communication Baud Rate 0 = 9600, 1 = 19200, 2 = 38400, 3 = 56000 ,4 = 57600,5=115200	R/W	16 bits int.	1

Notes:

1. The following flow rate units are available:

0. "m3" – Cubic Meter
1. "l" – Liters
2. "ga" – Gallons
3. "ig" – Imperial Gallons
4. "mg" – Million Gallons
5. "cf" – Cubic Feet
6. "ba" – US Barrels
7. "ib" – Imperial Barrels
8. "ob" – Oil Barrels

2. When the flowmeter address or communication baud rate change, the meter will work under the new address or communication baud rate after the communication baud rate responded with returned primary address and communication baud rate.

3. 16 bits int-short integer, 32 bits int-long integer, 32 bits real-floating point number, String-alphabetic